

# Agilent Turbo Pumps

Robust, industry-leading vacuum pumps and controllers for confidence across a broad range of applications



## Table of Contents

<b>Experience the Agilent Advantage</b>	<b>4</b>		
50 Years of expertise in vacuum science	4	TwisTorr 804 FS	38
Sustainability commitment	5	Turbo-V 1K-G	40
		Turbo-V 1001 Navigator	42
		Turbo-V 2K-G system	44
		Turbo-V 2300 TwisTorr	46
<b>Agilent Turbo Pumps Typical Applications</b>	<b>6</b>		
<b>Turbo Pumps: A Legacy of Excellence</b>	<b>6</b>	<b>Agilent Turbo Pump Controllers</b>	<b>48</b>
		TwisTorr 74/84 FS on-board controller	48
		TwisTorr 74/84 FS AG rack controller	49
		TwisTorr 305 FS remote controller	50
		TwisTorr Medium-TMP on-board controller	51
		TwisTorr Medium-TMP rack controller	52
		Turbo-V 1001 Navigator controller	53
		Turbo-V 1001 rack controller	54
		Turbo-V 2300 rack controller	55
<b>Ultra-high Vacuum and Physics Research (UHV)</b>	<b>8</b>		
<b>Solutions for Mass Spectrometry</b>	<b>9</b>	<b>Agilent Turbo Pump Accessories</b>	<b>56</b>
Vacuum solutions for GC/MS	9	Inlet screens	56
Vacuum solutions for LC/MS	10	Air cooling kits	56
Vacuum solutions for ICP/MS	10	Water cooling kits	56
Vacuum solutions for QTOF	10	Vibration dampers	57
		Turbo vent valve	57
		Purge valve	57
		Turbomolecular pump parameters and definitions	58
		Pump selection criteria	60
<b>Solutions for Analytical Electron Microscopes</b>	<b>11</b>		
Modal balancing	11		
IDX double damper	11		
Variable speed electronics	11		
<b>Solutions for Semiconductor Electron Microscopes</b>	<b>13</b>	<b>Agilent Molecular-Drag Technologies</b>	<b>61</b>
Long-standing partnership	13	TwisTorr technology	62
Full turbomolecular pump range	13	MacroTorr technology	62
Vibration damping solutions	13	Agilent Floating Suspension system	63
		AI enabled adaptive modal balancing	64
<b>Solutions for PVD and Advanced Materials</b>	<b>14</b>	<b>Agilent Vacuum Link App</b>	<b>65</b>
PVD thin film deposition and optical coatings	14		
<b>Solutions for e-Mobility and Other Industrial Applications</b>	<b>15</b>	<b>Agilent Turbo Pump Technical Notes</b>	<b>67</b>
e-Mobility batteries manufacturing	15	Agilent A-PLUS software	67
Vacuum load-locks	15	CE/CSA, EMC Specifications Compliance	67
<b>Agilent Turbo Pump Models</b>	<b>16</b>	<b>Agilent Services and Support</b>	<b>68</b>
Technical specification comparison chart	16	Service and Support plans	68
TwisTorr 74 FS	20	Contact Agilent	69
TwisTorr 84 FS	22		
TwisTorr 305FS and TwisTorr 305-IC	24		
TwisTorr 305 FSQ and TwisTorr 305-ICQ	26		
TwisTorr 404 FS	30		
Turbo V-551 Navigator	32		
TwisTorr 704 FS	36		





# Experience the Agilent Advantage

Imagine 1350 rotations per second, that's the incredible speed of the Agilent 80 l/s turbomolecular pump. To put it in perspective, when you're driving on a highway, your car's wheels turn about 15 times per second.

The turbo rotor spins nearly 100 times faster!

Agilent turbomolecular pumps are engineered to meet the most demanding vacuum applications across various industries, including analytical instrumentation, the semiconductor manufacturing, industrial sectors, and high-energy physics research facilities. These applications require top-tier vacuum performance, reliability, and cleanliness, supported by a service organization that offers rapid response 24/7. Achieving these standards is our daily mission.

## With over 50 years of expertise in vacuum science, Agilent is a market leader in innovative design solutions

Turbomolecular pumps are essential in high-energy physics, fusion technology, and general UHV research. Applications such as synchrotron light sources, particle accelerator rings, UHV laboratory research, and fusion reactors demand extremely clean, reliable, and cost-effective high and ultrahigh vacuum (HV and UHV) solutions. Given the inaccessibility of most pumps, maintenance-free operation is crucial.

Agilent turbomolecular pumps are engineered to deliver unparalleled reliability, performance, and cleanliness for these demanding applications. Ceramic bearing pumps, with reduced rolling friction, low stress, and high thermal stability, ensure a



## Agilent Advantage

Agilent turbo pumps are designed for reliability and optimum performance in real world applications to meet highest quality standard.

Find integrated pumping systems, multiflow pump solutions for scientific instruments, and dedicated solutions for vibration-sensitive applications in nanotechnologies.

<https://www.agilent.com/en/product/vacuum-technologies/turbo-pumps-controllers>



longer operating life compared to conventional bearings. The use of ultra-low vapor pressure solid lubricants eliminates the need for maintenance, ensuring clean operation under all conditions.

Unlike many other pumps, Agilent turbo pumps feature both upper and lower bearings located on the rough vacuum side, preventing exposure to UHV and significantly reducing contamination risks, even in cases of misuse. The patented TwisTorr stages provide the highest speed and compression ratio within the smallest footprint. Additionally, Agilent turbo pumps can be mounted in any orientation, from vertical to horizontal to upside down, facilitating system design in the most space-constrained environments.

Agilent turbo pumps can operate at higher foreline pressures, enabling the use of dry roughing pumps and offering a completely clean, oil-free, compact, and cost-effective pumping solution. For applications requiring high gas throughput, the combination of TwisTorr pumps and TriScroll dry pumps represents the state-of-the-art solution.

Agilent turbo pumps are available with integrated or onboard controllers for easy plug-and-pump operation, or with rack-mounted controllers for environments where remote electronics placement is necessary, such as radioactive settings.

For instrumentation, including electron microscopes (SEM, TEM), focused ion-beam systems (FIB), and surface analysis, Agilent offers a comprehensive range of high and ultrahigh vacuum pumps tailored to meet the stringent requirements of these applications. Our turbomolecular pumps provide fast, oil-free air evacuation of large sample chambers, a critical requirement in applications requiring modern analytical tools, like semiconductor manufacturing.

The Agilent full range of turbo pumps allows focused-beam system designers to select the optimal pump size for the best chamber evacuation time, cost of ownership, and compact size for limited space situations. We also offer customized, low-vibration turbo pumps for the most sensitive microscopy applications, along with integrated pump controllers that provide high-control flexibility with minimal electromagnetic noise generation.

Agilent application-specific SEM turbo pumps are available in various speeds, including 80, 300, 550, 700, and 1000 l/s, ensuring that all designs meet the highest standards of performance and reliability.

## Sustainability Commitment

At Agilent, we are committed to sustainability and environmental responsibility. Our turbomolecular pumps are designed with energy efficiency in mind, reducing power consumption and minimizing environmental impact. The use of maintenance-free, solid lubricants not only ensure clean operation but also reduces waste and the need for hazardous materials. By enabling the use of dry roughing pumps, our solutions help eliminate oil contamination, contributing to a cleaner and safer environment.

Furthermore, the long operating life and reliability of Agilent turbo pumps mean fewer replacements and less waste, supporting a more sustainable lifecycle. Our dedication to innovation and sustainability ensures that Agilent products not only meet the highest performance standards but also contribute to a greener future.



TwisTorr 305-IC and 305 FS

## Agilent Turbo Pumps: A Legacy of Excellence

With over 50 years of expertise, Agilent turbo pumps offer an unparalleled fusion of performance and features across a diverse spectrum of applications:

### Ultra-high Vacuum and Physics Research (UHV)

Agilent turbo pumps excel in creating and maintaining extremely low-pressure environments, essential for scientific research, precision manufacturing, and cutting-edge experiments.



### Mass Spectrometry (MS)

Turbo pumps play a pivotal role in MS instruments, ensuring accurate ionization and precise analysis. From pharmaceuticals to environmental monitoring, MS benefits from Agilent technology.



### Electron Microscopes (EM)

Agilent turbo pumps enhance imaging resolution and sample analysis in EM systems. Whether investigating materials or biological specimens or nanocircuits, these pumps elevate EM performance. Agilent turbo pumps are ideal for:

- General purpose analytical electron microscopes
- Semiconductor electron microscopes



### PVD and Advanced Materials (PVD)

Agilent turbo pumps contribute to thin-film deposition, surface modification, and plasma processes vital for industrial coatings, and beyond.



### Automotive and Other Industrial Applications

Agilent turbo pumps offer oil-free, clean vacuum for demanding industrial applications. In summary, Agilent's Turbopumps stand as a testament to innovation, reliability, and versatility across critical scientific and industrial domains.



## Making Advanced Science and Processes Possible

For many scientific inquiries and engineered processes, it is necessary to create evacuated workspaces. Creating, measuring, and maintaining such low-pressure conditions can be challenging and require several

technologies, as well as extremely careful design, preparation, and maintenance practices.

<https://www.agilent.com/en/solutions/vacuum-solutions>



TwisTorr  
74/84 FS



TwisTorr  
305 FS



TwisTorr  
704



TwisTorr  
804



Turbo-V  
1001



Turbo-V  
2300



TwisTorr  
74/84 FS



TwisTorr  
305 SF



Multi Flow  
Pumps



TwisTorr  
74/84 FS



TwisTorr  
305 FS



Turbo-V 551  
SEM



Turbo-V 701  
SEM



Turbo-V 1001  
SEM



Double Damper  
ISO200



TwisTorr  
305 FSQ



Turbo-V  
1K-G



Turbo-V  
2K-G



TwisTorr  
305 FSQ



Turbo-V  
551



Turbo-V  
701



Turbo-V 1K-G



Turbo-V  
2K-G



## Ultra-High Vacuum and Physics Research (UHV)

### Ultra-high Vacuum and Extreme High Vacuum. Where Advanced Research and Vacuum Technology Intersect

Whether isolating subatomic particles or simulating the conditions of space, ultrahigh and extreme high vacuum are at the center of the human search to understand the physical universe. The unique condition of such very low pressure, nearly devoid of matter, is almost never found on our planet and must be created using specialized equipment and techniques.

Mastering the creation and maintenance of vacuum is critical to the pursuit of advanced research of the natural world.

### Vacuum in Particle and Plasma Physics. Understanding How the Universe is Constructed

Particle and plasma physics are branches of the larger area defined as high energy physics (HEP). The goal of HEP is to explore what the world is made of and how it works on the smallest scale. Study of matter on this scale requires isolating subatomic particles in evacuated devices such as accelerators. The challenges of engineering such unique environments are considerable, as such, systems require the breadth of vacuum technologies to create, measure, and maintain the very low pressures required.

Agilent has been supporting scientific inquiry enabled by ultrahigh (UHV) and extreme high vacuum (XHV) for many decades. As the successor to Varian, which invented the ion getter pump that made UHV possible, Agilent remains committed to supporting physics exploration that expands collective knowledge of the physical world through continued innovation of vacuum technologies, products, and services.

#### Did you Know?

Discover how Agilent enables advanced research in particle and plasma physics:

<https://www.agilent.com/en/solutions/vacuum-solutions/particle-plasma-physics>

**TwisTorr 84 FS**



**TwisTorr 305 FSQ**



**Turbo-V 551**



**Turbo-V 701**



**Turbo-V 1001**





## Solutions for Mass Spectrometry

Mass spectrometry (MS) is an Agilent core business and has become a fundamental analytical tool in many industries. Thanks to advances in electronics, instrument designers can implement high-performance analytical power in a cost-effective, easy-to-use system. These developments require advanced vacuum systems characterized by multichamber, high-throughput designs on high-quality instruments. These requirements, in turn, demand cost-effective, high-performance vacuum pumps.

Agilent offers a full line of pumps and controllers that meet the most challenging vacuum requirements and are optimized for the specific requirements of modern mass spectrometry systems. Agilent can further customize its pumps by providing multi-inlet pumping systems that are compact and reliable.

### Vacuum Solutions for GC/MS

Gas chromatography mass spectrometers (GC/MS) typically use one vacuum chamber in relatively low gas load environments and an intermediate vacuum interface to analyze inorganic samples.

The Agilent TwisTorr 84 with On Board Controller or printed circuit board controller (PCB) is a very cost-effective solution for this common analytical technique. The TwisTorr 305 offers a compact, cost-effective solution for larger instrument designs.

**TwisTorr 74/84 FS**



**TwisTorr 305 SF**



### Did you Know?

Agilent has a full line of products for analytical instrumentation and Laboratories. Please visit:

<https://www.agilent.com/cs/library/brochures/brochure-vacuum-solutions-analytical-instrumentation-5994-0681en-agilent.pdf>



# Agilent Turbo Pumps Typical Applications



## Vacuum Solutions LC/MS

Liquid chromatography mass spectrometers typically include multichamber, high-throughput vacuum systems. The Agilent multiflow turbomolecular pumps are designed for high-throughput operation with air cooling which is an important benefit for maintaining a compact system. They are also available several multiflow versions to increase their utility and performance in this application.

The integrated controller provides a high level of control function in a small package.



## Vacuum Solutions ICP-MS

Inductively Coupled Plasma-MS systems have a wide range of vacuum requirements. Many systems can use heavy carrier gases such as argon, while collision cell designs use helium.

Agilent turbo pumps have a high efficiency motor and TwisTorr or MacroTorr drag stages to reduce heat production under gas load. These features allow the system to pump high levels of argon. Integrated or onboard controllers assure a compact package.



## Vacuum Solutions Q-TOF

Time-of-flight (TOF) systems are becoming very important analytical tools in drug discovery and proteomics. Vacuum requirements vary, although small size is often an important consideration.

Agilent turbo pump and controller package provides the TOF designer with a high degree of flexibility with regard to high throughput, efficient heat dissipation and compact size.

## Multi Flow Pumps



## Did you Know?

Agilent can offer you a complete set of vacuum solutions for Analytical Labs, including Oil-Free primary pumps, suitable for the most popular analytical instruments? Check our Analytical V4L Vacuum for Lab solutions catalog.

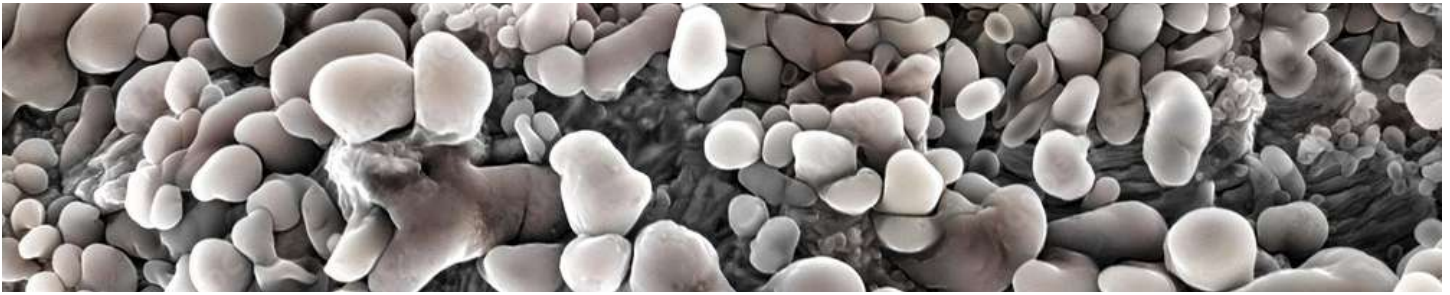

## Solutions for Analytical Electron Microscopes

### Agilent Optimized Turbomolecular Pumping Solutions for Analytical and General Purpose Scanning Electron Microscopes (SEMs).

With extensive experience collaborating with major electron microscope manufacturers, Agilent offers a comprehensive range of turbomolecular pumps. Regardless of your SEM model, we provide solutions based on our TwisTorr 84 FS and TwisTorr 305 FS platforms, meeting stringent vibration requirements.

Noteworthy features of Agilent turbomolecular pumps for SEM include:

#### **Modal Balancing:**

A novel balancing technology minimizes vibration and noise during both full-speed operation and speed transients. Users benefit from a remarkably quiet experience and consistent vibration levels over time.

#### **IDX Double Damper:**

The Agilent patented damper optimally dampens vibrations at low and high frequencies.

Tuned to the pump mass and vibration characteristics, it ensures an ideal damping rate at any working point. Additionally, the unique design electrically insulates the pump from the system, preventing potential "ground loops" that could introduce artifacts in SEM images.

#### **Variable Speed Electronics:**

Agilent SEM turbo pumps feature digital control units, allowing precise adjustment of turbo pump rotation speed. This flexibility helps avoid coupling between pump vibrations and system-level natural modes.

Our experts are available for troubleshooting vibration and resonance issues.

In summary, Agilent turbomolecular pumps enhance SEM performance by minimizing noise, optimizing damping, and ensuring reliable operation.

#### **TwisTorr 84 FS**



Part number X3502-64010

#### **TwisTorr 305 FS**



X3513-64008



## Integrated Double Damper

Part number 9699396



Agilent's patented Double Damper provides optimal vibration damping to the pump vibration signatures, to accommodate both low and high frequencies ranges. Additionally, the design grants electrical insulation to minimize possible electric systems ground loops through the pump, contributing to an artifact-free, better SEM image.

## Did you Know?

Agilent is offering a complete line of ion pumps and control units specific for electron microscopes columns and field emission sources.

Get in touch with our Contact Centers for more information

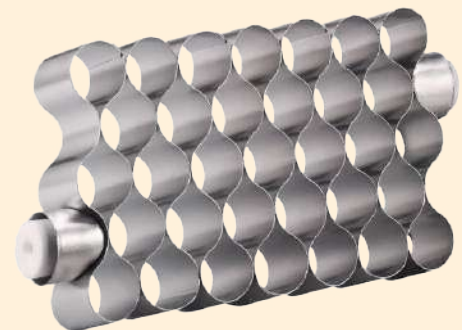

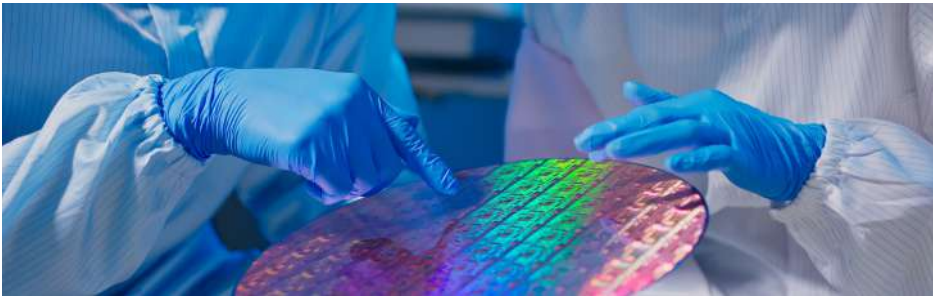

## Solutions for Semiconductor Electron Microscopes

Agilent provides a comprehensive range of turbomolecular pumping solutions specifically designed for electron microscopes (ems) used in the semiconductor production industry. These solutions cater to various EM types, including CD-SEM, DR-SEM, and eBeam-based wafer inspection systems.

Here are the key points about the Agilent offerings:

### Long-standing Partnership:

Agilent has been a trusted partner of SEM manufacturers since the early days of the semiconductor industry. This collaboration has allowed Agilent to develop tailored solutions that meet the stringent requirements of electron microscopes used in integrated circuits (IC) manufacturing workflows.

### Full Turbomolecular Pumps Range:

Agilent's Turbomolecular pumps cover a wide range, from 70 to 1000 l/s (liters per second).

These pumps play a crucial role in maintaining vacuum conditions within the SEM chambers, ensuring optimal imaging and analysis.

### Vibration Damping Solutions:

Agilent unique design solutions focus on minimizing vibration and noise.

Notably, the Double Dampers, available for ISO100, ISO 160, and ISO 200 flange sizes, provide optimal damping at both low and high frequencies. These dampers are precisely tuned to the pump models, vibration parameters, and natural frequencies, resulting in effective vibration reduction.

In summary, Agilent specialized turbomolecular pumping solutions enhance the performance and reliability of SEMs in semiconductor manufacturing, contributing to precise imaging and analysis.

**Turbo-V 551SEM**



**Turbo-V 701SEM**



**Turbo-V 1001SEM**



**Double Damper ISO200**



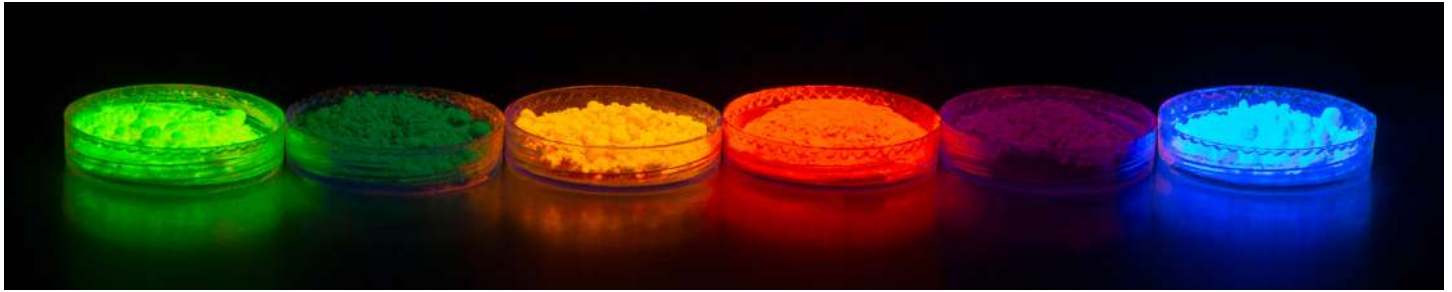

## Solutions for PVD and Advanced Materials

### Solutions for PVD Thin Film Deposition - Optical Coatings

In diverse industries, spanning from glass coating to tools sterilization, manufacturers universally seek robust and reliable vacuum technologies.

Agilent, with a keen focus on total cost of ownership, consistently pioneers innovative vacuum solutions. These cutting-edge systems not only maximize throughput but also thrive under challenging and variable operating conditions, while simultaneously simplifying maintenance to ensure optimal uptime and efficiency.



The Agilent K-G turbo pumps, purpose-built for heavy industrial use, exhibit remarkable resilience.

They effortlessly handle high gas loads and swiftly recover from accidental air in-rushes.

Notably, Agilent offers a distinctive line of turbo pumping systems meticulously tailored for argon pumping and plasma applications with the Turbo-V 1K-G and Turbo-V 2K-G.

These specialized pumps are optimized for argon and other heavy molecules, commonly encountered in PVD-based processes. Their standout features include superior throughput, precise thermal control, substantial power capacity, and air-inrush protection.

But these are no ordinary turbo pumps. The Agilent K-G line seamlessly integrates critical components: The electronics, vent valve, and purge valves are all encased in rugged aluminum for maximum durability and uptime.

This comprehensive package makes the K-G line the ideal pumping solution for lens coaters, roll-to-roll coaters, and various other PVD industrial applications.

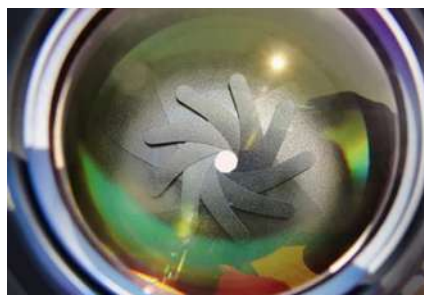

### Turbo-V 1K-G



### Turbo-V 2K-G





## Solutions for e-Mobility and Other Industrial Applications

### e-Mobility Batteries Manufacturing

Roll-to-roll processing is a sophisticated fabrication technique employed in manufacturing. It involves continuous handling of flexible substrates, such as thin films or sheets, as they move through a series of precisely orchestrated steps. Roll-to-roll coaters handle diverse materials; however, their most recent application is in energy storage where they are a fundamental enabling technology for manufacturing battery electrodes. Agilent has a complete portfolio of turbomolecular pumps for roll-to-roll applications including the TwisTorr 305FSQ, Turbo-V line and the Turbo K-G line.



Note: Agilent offers an e-Mobility application, including leak detectors, diffusion pumps and more.



### Vacuum Load-Locks

A wafer cassette load-lock serves as a critical interface within semiconductor manufacturing environments. Its purpose is to facilitate the transfer of semiconductor wafers, loaded in cassettes, between different process chambers while maintaining a controlled environment. Load-locks play a crucial role in wafer processing steps, such as deposition, etching, and lithography. Agilent has a broad range of turbomolecular pumps designed for rapid cycling and fast pump down time.

Looking to reduce load lock pump down time? Please check the Agilent TwisTorr 305 line and Turbo-V line

**Turbo-V 551**



**Turbo-V 701**



**Turbo-V 1001**



**TwisTorr 305 FSQ**



# Agilent Turbo Pump Models

		TwisTorr 74 FS		TwisTorr 84 FS		TwisTorr 305 FS
<b>Flange Size</b>		KF 40	ISO 63	KF 40	ISO 63	ISO 100 K / CFF 6" ISO 160 K / CFF 8"
<b>Pumping Speed, L/s</b>	H <sub>2</sub>	28	42	36	53	220 L/s
	He	33	54	38	63	255 L/s
	N <sub>2</sub>	44	60	49	67	250 L/s
	Ar	40	59	44	66	250 L/s
<b>Compression Ratio</b>	H <sub>2</sub>	1.0 x 10 <sup>9</sup>		≥1 x 10 <sup>11</sup>		1.5 x 10 <sup>6</sup>
	He	2.0 x 10 <sup>5</sup>		2 x 10 <sup>6</sup>		> 1 x 10 <sup>8</sup>
	N <sub>2</sub>	1.0 x 10 <sup>4</sup>		5 x 10 <sup>4</sup>		> 1 x 10 <sup>11</sup>
	Ar	> 1.0 x 10 <sup>9</sup>		>1 x 10 <sup>11</sup>		> 1 x 10 <sup>11</sup>
<b>Base Pressure, mbar</b>	With recommended mechanical pump	< 5 x 10 <sup>-10</sup>		<5 x 10 <sup>-10</sup>		<1 x 10 <sup>-10</sup> mbar (<1 x 10 <sup>-10</sup> Torr)
	With recommended dry pump	< 3.75 x 10 <sup>-10</sup>		<5 x 10 <sup>-10</sup>		
<b>Startup Time, min</b>		< 2		< 2		< 3 min (longer when soft start is used)
<b>Recommended Forepump</b>	Mechanical pump	DS 40M, DS 102		DS 40M, DS 102		DS102, DS302
	Dry pump	IDP-3, IDP-7		IDP-3, IDP-7, IDP-10		IDP-3 (no gas flow), IDP-7, IDP-10,
<b>Foreline Flange, Nominal Diameter</b>	Klamp flange	KF16 NW		KF16 NW		KF16 NW (KF25 NW - optional)



TwisTorr 74 FS



TwisTorr 84 FS



TwisTorr 305 FS

		TwisTorr 305 FSQ	TwisTorr 305-IC	TwisTorr 305-ICQ	TwisTorr 404 FS
<b>Flange Size</b>		ISO 100 K	ISO 100 K / CFF 6" ISO 160 K / CFF 8"	ISO 100 K	ISO 100 KF CFF6"
<b>Pumping Speed, L/s</b>	H <sub>2</sub>	220 L/s	220 L/s	220 L/s	445 l/s
	He	255 L/s	255 L/s	255 L/s	470 l/s
	N <sub>2</sub>	250 L/s	250 L/s	250 L/s	355 l/s
	Ar		250 L/s		320 l/s
<b>Compression Ratio</b>	H <sub>2</sub>	2 x 10 <sup>4</sup>	1.5 x 10 <sup>6</sup>	2 x 10 <sup>4</sup>	>10 mbar
	He	1 x 10 <sup>5</sup>	> 1 x 10 <sup>8</sup>	1 x 10 <sup>5</sup>	>10 mbar
	N <sub>2</sub>	2 x 10 <sup>8</sup>	> 1 x 10 <sup>11</sup>	2 x 10 <sup>8</sup>	>4 mbar
	Ar		> 1 x 10 <sup>11</sup>		>8.5 mbar
<b>Base Pressure With Recommended Forepump</b>		<1 x 10 <sup>-10</sup> mbar (<1 x 10 <sup>-10</sup> Torr)	<1 x 10 <sup>-10</sup> mbar (<1 x 10 <sup>-10</sup> Torr)	<1 x 10 <sup>-10</sup> mbar (<1 x 10 <sup>-10</sup> Torr)	<1 x 10 <sup>-10</sup> mbar (<1 x 10 <sup>-10</sup> Torr)
<b>Startup Time, min</b>		< 3 min (longer when soft start is used)	< 3 min (longer when soft start is used)	< 3 min (longer when soft start is used)	< 5 min
<b>Recommended Forepump</b>	Mechanical pump	DS102, DS302	DS102, DS302	DS102, DS302	DS302
	Dry pump	IDP-3 (no gas flow), IDP-7, IDP-10,	IDP-3 (no gas flow), IDP-7, IDP-10,	IDP-3 (no gas flow), IDP-7, IDP-10,	IDP-10
<b>Foreline Flange, Nominal Diameter</b>	Klamp flange	KF16 NW (KF25 NW - optional)	KF16 NW (KF25 NW - optional)	KF16 NW (KF25 NW - optional)	KF25 NW (KF16 NW as optional accessory)



TwisTorr 305 FSQ



TwisTorr 305-IC



TwisTorr 305-ICQ



TwisTorr 404 FS

# Agilent Turbo Pump Models

		Turbo V-551 Navigator		Turbo-V 701 Navigator	TwisTorr 704 FS	TwisTorr 804 FS
<b>Flange Size</b>		ISO100K CFF6"	ISO160 K CFF8"	ISO200 K-F CFF10"	ISO100K-F CFF8"	ISO200K-F, ISO250K-F, CFF10"
<b>Pumping Speed, L/s</b>	H <sub>2</sub>	450	510	510 L/s	480 L/s	485 L/s
	He	450	600	620 L/s	640 L/s	660 L/s
	N <sub>2</sub>	350	550	690 L/s	660 L/s	720 L/s
	Ar				625 L/s	690 L/s
<b>Compression Ratio</b>	H <sub>2</sub>	>1 x 10 <sup>9</sup>		1 x 10 <sup>6</sup>	>4 mbar	>4 mbar
	He	1 x 10 <sup>7</sup>		1 x 10 <sup>7</sup>	10 mbar	10 mbar
	N <sub>2</sub>	1 x 10 <sup>6</sup>		1x 10 <sup>9</sup>	10 mbar	10 mbar
	Ar				8.5 mbar	8.5 mbar
<b>Base Pressure with Recommended Fore-pump</b>	With recommended mechanical pump	<1 x 10 <sup>-10</sup>		<1 x 10 <sup>-10</sup> mbar (<1 x 10 <sup>-10</sup> Torr)	<1 x 10 <sup>-10</sup> mbar (<1 x 10 <sup>-10</sup> Torr)	<1 x 10 <sup>-10</sup> mbar (<1 x 10 <sup>-10</sup> Torr)
	With recommended dry pump	<1 x 10 <sup>-10</sup>				
<b>Startup Time, min</b>		< 5		< 5 min	< 5 min	< 5 min
<b>Recommended Forepump</b>	Mechanical pump	DS 102		DS302	DS302	DS302
	Dry pump	IDP-7, IDP-10		IDP-15, TS300	IDP-10, IDP15, TS300	IDP-10, IDP15, TS300
<b>Foreline Flange, Nominal Diameter</b>	Klamp flange	KF25 NW		KF25 NW	NW25 (NW40 as optional accessory)	NW25 or NW40



Turbo V-551 Navigator



Turbo-V 701 Navigator



TwisTorr 704 FS



TwisTorr 804 FS

		Turbo-V 1K-G		Turbo-V 1001 Navigator		Turbo-V 2K-G System	Turbo-V 2300 TwissTorr	
Flange Size		ISO160 F	ISO200 F	CFF8" ISO160 K	CFF10" ISO250 K-F	ISO250 K-F	ISO250 F	CFF12" ISO250 F
Pumping Speed, L/s	H <sub>2</sub>	680	730	860	900	920	-	1500
	He	950	1150	820	870	900	-	1800
	N <sub>2</sub>	810	1080	790	950	1050	1600	2050
	Ar	750	1040				-	
Compression Ratio	H <sub>2</sub>	1.5 x 10 <sup>4</sup>		1 x 10 <sup>6</sup>		-	4 x 10 <sup>4</sup>	
	He	>4 x 10 <sup>4</sup>		1 x 10 <sup>7</sup>		-	8 x 10 <sup>5</sup>	
	N <sub>2</sub>	>5 x 10 <sup>7</sup>		1 x 10 <sup>9</sup>		3x10 <sup>5</sup>	>8 x 10 <sup>8</sup>	
	Ar	>5 x 10 <sup>8</sup>		-		-	-	
Base Pressure with Recommended Forepump		<1 x 10 <sup>-10</sup> mbar (<1 x 10 <sup>-10</sup> Torr)		<1 x 10 <sup>-10</sup> mbar (<1 x 10 <sup>-10</sup> Torr)		<1 x 10 <sup>-8</sup> mbar (<1 x 10 <sup>-8</sup> Torr)	10 <sup>-10</sup>	
Startup Time, min		< 5		< 4		< 7	< 6	
Recommended Fforepump	Mechanical pump	>20 m <sup>3</sup> /h	>36 m <sup>3</sup> /h	DS402		>40 m <sup>3</sup> /h	DS602	
	Dry pump	TS600		IDP-15			TS600	
Foreline Flange, Nominal Diameter	Klamp flange	KF25 NW	KF40 NW	KF40 NW		KF40 NW	KF40 NW	



Turbo-V 1K-G



Turbo-V 1001 Navigator



Turbo-V 2K-G System



Turbo-V 2300 TwissTorr

# Agilent Turbo Pump Models

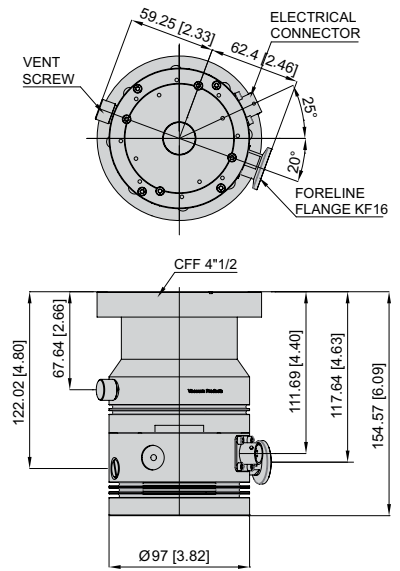
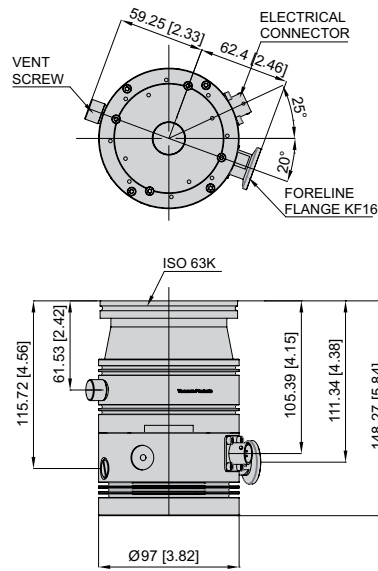

Dimensions: millimeters [inches]

## TwisTorr 74 FS

### Technical Specification

Pumping Speed	KF40	CFF 2.75"	ISO 63	CFF 4.5"
N <sub>2</sub>	44 L/s	50 L/s	60 L/s	60 L/s
He	33 L/s	40 L/s	54 L/s	54 L/s
H <sub>2</sub>	28 L/s	31 L/s	42 L/s	42 L/s
Ar	40 L/s	51 L/s	59 L/s	59 L/s
Max Gas Throughput (Backing pump 5 m <sup>3</sup> /h)	Air cooling (35 °C ambient temperature)		Water cooling (25 °C water temp./ 35° ambient temp.)	
	N <sub>2</sub>	130 sccm	130 sccm	
Ar	80 sccm	80 sccm		
<b>Compression Ratio and Foreline Tolerance</b>				
N <sub>2</sub>	1.0 x 10 <sup>9</sup>		>12 mbar	
He	2.0 x 10 <sup>5</sup>		>10 mbar	
H <sub>2</sub>	1.0 x 10 <sup>4</sup>		>4 mbar	
Ar	> 1.0 x 10 <sup>9</sup>		>14 mbar	
Base Pressure with Recommended Forepump	< 5 x 10 <sup>-10</sup> mbar (< 3.75 x 10 <sup>-10</sup> Torr)			
Inlet Flange	KF 40, ISO 63, CFF 4, 5", CFF 2.75"			
Foreline Flange	KF16 NW			
Rotational Speed	70000 rpm (1167 Hz driving frequency)			
Start-Up Time	< 2 minutes			
Recommended Forepump	Mechanical: Agilent DS 40M / DS 102 Dry pump: Agilent IDP-3 / IDP-7			
Operating Position	Any			
Oper. Ambient Temperature	+5 to +35 °C			
Rel. Humidity of Air	0 - 90 % (not condensing)			
Bakeout temperature	80 °C for ISO (120 °C for CFF) at inlet flange			

Lubricant	Permanent lubrication
Cooling Requirements	Forced air (5- 35 °C ambient temperature)
Air Cooling	Air flow temperature +5 to +35 °C
Water Cooling	Cooling water temperature: +15 to +25 °C Minimum flow: 65 L/h
Noise Pressure level (at 1 mt at full speed)	40 dB(A)
Storage Temperature	-40 to +70 °C
Max Altitude	3000 m
Weight kg (lbs)	Pump ISO 63: 2.05 kg (4.50) Pump CFF 4.5": 3.50 kg (7.70) Pump CFF 2.75": 3.34 kg (7.35) Pump KF 40: 2.37 kg (5.22)

**Conformity to Norms** CE, C-CSA-US, RoHS compliant as per 2011/65/UE

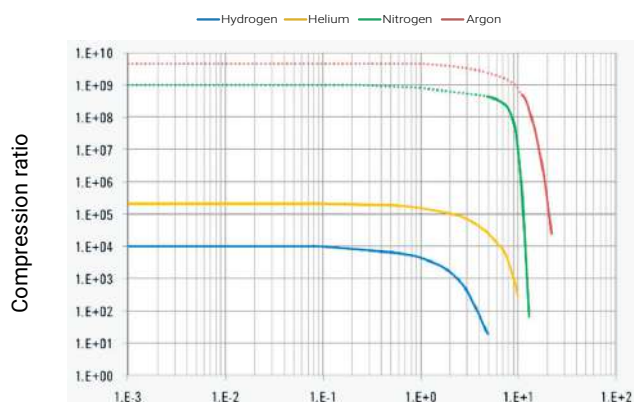

Foreline Pressure (mbar)  
Compression ratio vs foreline pressure

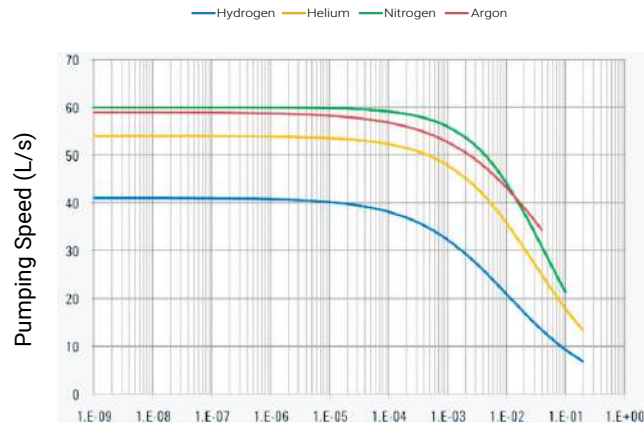

Inlet Pressure (mbar)  
Pumping speed vs inlet pressure

## Ordering Information

Pumps	Part Number
TwisTorr 74 FS ISO 63	X3502-64170
TwisTorr 74 FS KF 40	X3502-64171
TwisTorr 74 FS CFF 4.5"	X3502-64172
TwisTorr 74 FS CFF 2.75"	X3502-64173
Controllers	
TwisTorr 74 FS AG rack controller RS232/485	X3508-64301
TwisTorr 74 FS AG rack controller Profibus	X3508-64022
TwisTorr 74 FS onboard controller 110/220 V	X3509-64030
TwisTorr 74 FS onboard controller 24 VDC	X3509-64021
TwisTorr 74 FS PCB controller	X3510-64050
Cables	
Mains cable NEMA plug 3 m long	9699958
Mains cable EU plug 2.5 m long	9699957
Mains cable UK plug 3 m long	X3501-68005
Mains cable China plug 3 m long	X1699-64144
RS232 serial cable and A-PLUS software, 3 m long	9699883
Power cable, 1 m long, 24 V	9699869
Extension cable*	9699942 (3 m)
	9699942M007 (5 m)
	9699942M006 (10 m)
	9699942M005 (15 m)
	9699942M004 (20 m)
Inlet Screen	
Inlet screen ISO 63	X3502-68001
Inlet screen CFF 4.5"	X3502-68000
Inlet screen, KF 40	9699309
Inlet screen CFF 2.75"	9699328
Cooling	
Metal water cooling kit	X3502-68002
Plastic water cooling kit	X3502-68003
Air cooling kit (0,5 m cable)	9699290
Air cooling kit extension cable (5 m)	9699940

## Vibration Isolator

Vibration isolator ISO 63	9699375
Vibration isolator CFF 4.5"	9699376

## Venting

Vent valve N.O. 0.5 mm orifice (0.7 m cable)	9699844
Vent valve extension cable	9699941 (5 m)
	9699941M003 (10 m)
	9699941M001 (15 m)
	9699941M005 (20 m)
	9699941M007 (30 m)
	9699941M004 (50 m)
Vent screw M5	X3502-68005
Vent valve adapter M5-M8	X1699-64039

## Purge

Purge screw	X3502-68004
Purge valve 10 SCCM NW16KF - M12	9699239
Purge valve 10 SCCM ¼ Swagelok - M12	9699240
Purge valve 20 SCCM NW16KF - M12	9699241
Purge valve 20 SCCM ¼ Swagelok - M12	9699242
Purge valve 10 SCCM ¼ Swagelok - 7/16-20 male threads	9699232
Purge valve 20 SCCM ¼ Swagelok - 7/16-20 male threads	9699236

## Mounting

Controller side mounting bracket	X3502-68006
CFF 4.5 Mounting kit	X3502-68007
Metric screws kit	X3502-68008
American screws kit	X3502-68009

## Active Gauges

FRG-700 full range gauge	
PVG-500 Pirani vacuum gauge	Ask Agilent for details
PCG-750 Pirani capacitance gauge	
CDG-500 capacitance diaphragm gauge	

\*For a complete list of available extension cables, see the [Extension Cables for Turbo Pumps dedicated page](#) on Agilent.com.

# Agilent Turbo Pump Models

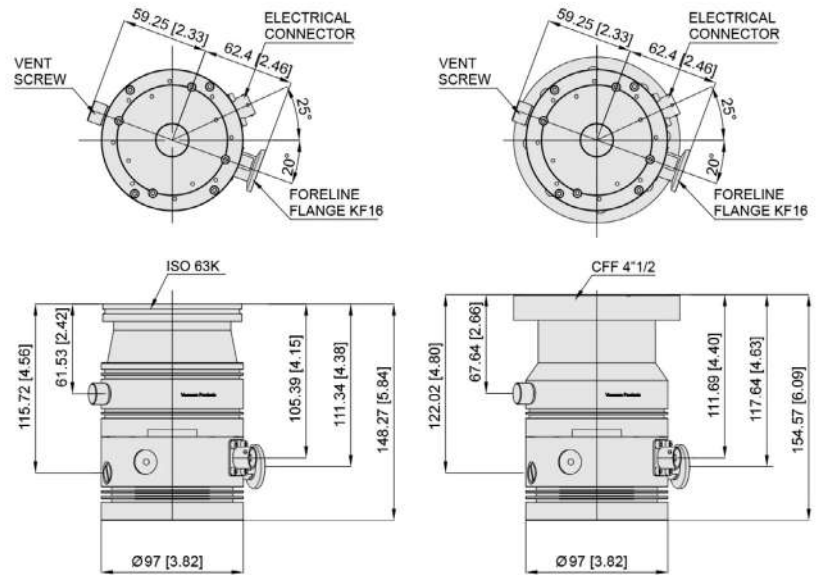

Dimensions: millimeters [inches]

## TwisTorr 84 FS

### Technical Specification

Pumping Speed	KF40	CFF 2.75"	ISO 63	CFF 4.5"
N <sub>2</sub>	49 L/s	56 L/s	67 L/s	67 L/s
He	38 L/s	46 L/s	63 L/s	63 L/s
H <sub>2</sub>	36 L/s	40 L/s	53 L/s	53 L/s
Ar	44 L/s	57 L/s	66 L/s	66 L/s
Gas Throughput At Full Rotational Speed (with recomm. forepump)	Air cooling (35 °C)		Water cooling (25 °C, 65 L/h)	
N <sub>2</sub>	100 SCCM		100 SCCM	
Ar	70 SCCM		70 SCCM	
Compression Ratio and Foreline Tolerance				
N <sub>2</sub>	70 a ≥ 1.0 x 10 <sup>11</sup>		>14 mbar	
He	2.0 x 10 <sup>6</sup>		>12 mbar	
H <sub>2</sub>	5.0 x 10 <sup>4</sup>		>4 mbar	
Ar	> 1.0 x 10 <sup>11</sup>		>14 mbar	
Base Pressure with Recommended Forepump (5 m <sup>3</sup> /h)	< 5 x 10 <sup>-10</sup> mbar (< 3.75 x 10 <sup>-10</sup> Torr)			
Inlet Flange	CFF 4.5" OD CFF 2.75" OD		ISO 63 KF 40	
Foreline Flange	KF16 NW			
Rotational Speed	81.000 rpm (1350 Hz driving frequency)			
Start-Up Time	< 2 minutes			
Recommended Forepump	Mechanical: Agilent DS 40M / DS 102 Dry pump: Agilent IDP-3 / IDP-7			
Operating Position	Any			
Oper. Ambient Temperature	+5 to +35 °C			
Rel. Humidity Of Air	0 - 90 % (not condensing)			

<b>Bakeout temperature</b>	80 °C for ISO (120 °C for CFF) at inlet flange
<b>Lubricant</b>	Permanent lubrication
<b>Cooling Requirements</b>	Forced air (5- 35 °C ambient temperature)
<b>Air Cooling</b>	Air flow temperature +5 to +35 °C
<b>Water Cooling</b>	Cooling water temperature: +15 to +25 °C Minimum flow: 65 L/h (0.30 GPM) Pressure: 2 to 4 bar (45 to 75 psi)
<b>Noise Pressure Level (at 1 mt at full speed)</b>	40 dB(A) *
<b>Storage Temperature</b>	-40 °C to +70 °C
<b>Max Altitude</b>	3000 m
<b>Weight kg (lbs)</b>	Pump ISO 63: 2.05 kg (4.50) Pump CFF 4.5: 3.50 kg (7.70) Pump CFF 2.75: 3.34 kg (7.35) Pump KF 40: 2.37 kg (5.22)
<b>Conformity to Norms</b>	CE, C-CSA-US, RoHS compliant as per 2011/65/UE

\*average value ± 4 dB(A) std deviation

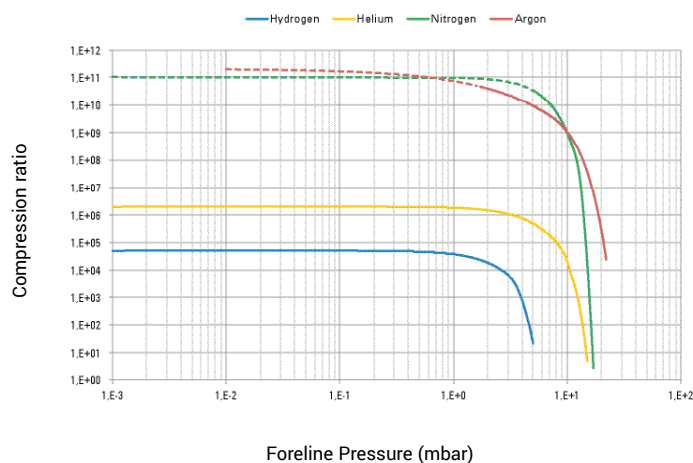

Compression ratio vs foreline pressure

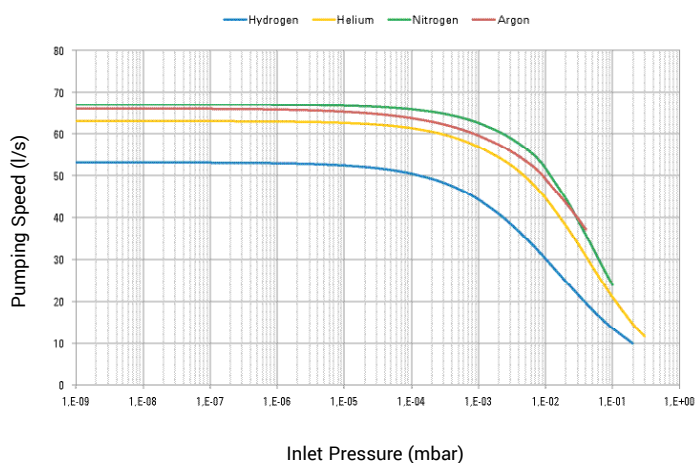

Pumping speed vs inlet pressure

## Ordering Information

Pumps	Part Number
TwisTorr 84 FS ISO 63	X3502-64000
TwisTorr 84 FS KF 40	X3502-64001
TwisTorr 84 FS CFF 4.5"	X3502-64002
TwisTorr 84 FS CFF 2.75"	X3502-64003
Controllers	
TwisTorr 84 FS AG rack controller RS232/485	X3508-64001
TwisTorr 84 FS AG rack controller Profibus	X3508-64002
TwisTorr 84 FS onboard controller 110/220 V	X3509-64000
TwisTorr 84 FS onboard controller 24 VDcT	X3509-64001
TwisTorr 84 FS PCB Controller	X3510-64000
Cables	
Mains cable NEMA plug 3 m long	9699958
Mains cable EU plug 3 m long	9699957
Mains cable UK plug 2.5 m long	X3501-68005
Mains cable China plug 3 m long	X1699-64144
RS232 serial cable and A-PLUS software, 3 m long	9699883
Power cable, 1 m long, 24 V	9699869
Extension cable*	9699942 (3 m)
	9699942M007 (5 m)
	9699942M006 (10 m)
	9699942M005 (15 m)
	9699942M004 (20 m)
Inlet Screen	
Inlet screen ISO 63	X3502-68001
Inlet screen CFF 4.5"	X3502-68000
Inlet screen, KF 40	9699309
Inlet screen CFF 2.75"	9699328
Cooling	
Metal water cooling kit	X3502-68002
Plastic water cooling kit	X3502-68003

Air cooling kit (0,5 m cable)	9699290
Air cooling kit extension cable (5 m)	9699940
Vibration isolator	
Vibration isolator ISO 63	9699375
Vibration isolator CFF 4.5"	9699376
Venting	
Vent valve N.O. 0.5 mm orifice (0.5 m cable)	9699844
Vent valve extension cable	9699941 (5 m)
	9699941M003 (10 m)
	9699941M001 (15 m)
	9699941M005 (20 m)
Vent screw M5	X3502-68005
Vent adapter kit M5-M8	X1699-64039
Purge	
Purge screw	X3502-68004
Purge valve 10 SCCM NW16KF - M12	9699239
Purge valve 20 SCCM NW16KF - M12	9699241
Purge valve 20 SCCM ¼ Swagelok - M12	9699242
Purge valve 10 SCCM ¼ Swagelok - ¼ Swagelok	9699232
Purge valve 20 SCCM ¼ Swagelok - ¼ Swagelok	9699236
Mounting	
Controller side mounting bracket	X3502-68006
CFF4.5 Mounting kit	X3502-68007
Metric screws kit	X3502-68008
American screws kit	X3502-68009
Active Gauges	
FRG 700 full range gauge	
PVG 500 Pirani vacuum gauge	Ask Agilent for details
PCG 750 Pirani capacitance gauge	
CDG-500 capacitance diaphragm gauge	

\*For a complete list of available extension cables, see the [Extension Cables for Turbo Pumps dedicated page](#) on Agilent.com.

# Agilent Turbo Pump Models



TwisTorr 305 FS

TwisTorr 305-IC

## TwisTorr 305 FS and TwisTorr 305-IC

### Technical Specifications

<b>Pumping Speed</b>	ISO 100 K / CFF 6" / ISO 160 K / CFF 8"	
H <sub>2</sub>	220 L/s	
He	255 L/s	
N <sub>2</sub>	250 L/s	
Ar	250 L/s	
<b>Max Gas Flow Rate</b>	N <sub>2</sub> 250 SCCM	
Note: values refer to water-cooling pump version with: - water temperature between 15 and 20 °C (non condensing) - backing pump with pumping speed equal or above 5 m <sup>3</sup> /h		
<b>Compression Ratio</b>	H <sub>2</sub> 1.5 x 10 <sup>6</sup> He > 1 x 10 <sup>8</sup> N <sub>2</sub> > 1 x 10 <sup>11</sup> Ar > 1 x 10 <sup>11</sup>	
<b>Max Foreline Pressure Tolerance</b>	N <sub>2</sub> 12 mbar	
Note: Foreline tolerance defined as the pressure at which the turbo pump still produce a compression of 100. For continuous operation, water cooling is recommended (water temperature between 15 and 20 °C).		

<b>Base Pressure with Recommended Forepump</b>	<1 x 10 <sup>-10</sup> mbar (<1 x 10 <sup>-10</sup> Torr)	
According to standard DIN 28 428, the base pressure is that measured in a leak-free test dome, 48 hours after the completion of test dome bake-out, with a turbo pump fitted with a ConFlat flange and using the recommended pre-vacuum pump.		
<b>Inlet Flange</b>	ISO 100 K, CFF 6", ISO 160 K, CFF 8"	
<b>Foreline Flange</b>	KF16 NW (KF25 - optional)	
<b>Max Rotation Speed</b>	60.600 rpm (1010 Hz driving frequency)	
<b>Start-Up Time</b>	< 3 minutes (longer when soft start is used)	
<b>Recommended Forepump</b>	Dry pumps: IDP-3 (no gas flow), IDP-7, IDP-10, Mechanical: DS102, DS302	
<b>Operating Position</b>	Any	
<b>Oper. Ambient Temperature</b>	+5 to +35 °C	
<b>Bakeout Temperature</b>	ISO flange: 75 °C at inlet flange max CFF flange: 100 °C at inlet flange max  Note: Measure a point close to the sealing element.	
<b>Lubricant</b>	Permanent lubrication	
<b>Cooling Requirements:</b>		
<b>Air Cooling</b>	Natural convection (only with no gas load) Forced air (5 - 35 °C ambient temperature)	
<b>Water Cooling</b>	Minimum flow: 50 L/h (0.22 GPM) Temperature: +15 °C to +30 °C Max pressure: 5 bar (75 psi)	
<b>Noise Pressure Level (at 1m at full speed)</b>	41 dB(A)	
Note: mean values based on a significative sample. (Ar and N <sub>2</sub> compression ratio estimated); standard deviation per test: pumping speed: below ± 7%; noise pressure level: ± 10% (only pump).		
<b>Installation Category</b>	II	
<b>Pollution Degree</b>	2	
<b>Storage Temp.</b>	-40 to +70 °C	
<b>Max Altitude</b>	3000 m	
<b>Weight kg (lbs)</b>	ISO 100 K	5.74 (12.6)
<b>TwisTorr 305-IC</b>	CFF 6"	8.06 (17.7)
	ISO 160 K	6.18 (13.6)
	CFF 8"	10.33 (22.7)
<b>Weight kg (lbs)</b>	ISO 100 K	5.84 (12.8)
<b>TwisTorr 305 FS</b>	CFF 6"	8.16 (17.9)
	ISO 160 K	6.28 (13.8)
	CFF 8"	10.43 (22.9)

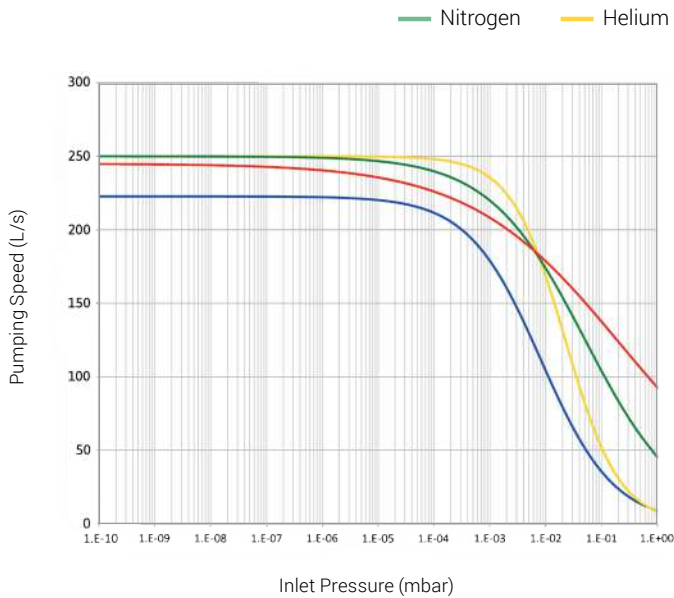

TwisTorr 305 FS and TwisTorr 305-IC Pumping Speed

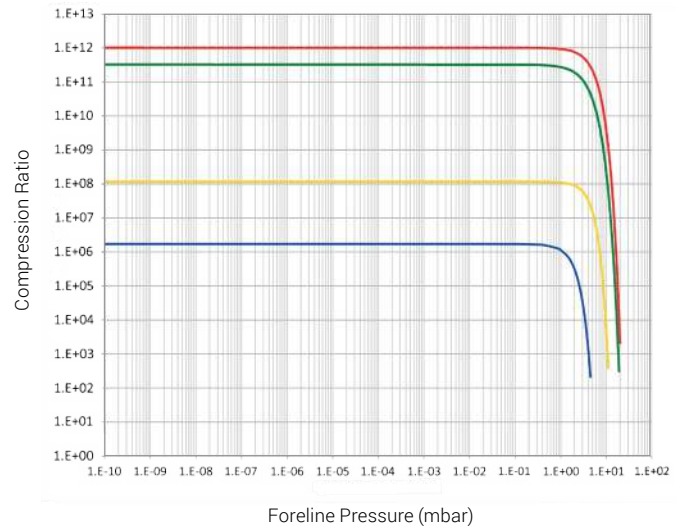

TwisTorr 305 FS and TwisTorr 305-IC Compression Ratio

**Technical Specifications**

**Remote Controller**

Voltage	100 - 240 Vac (voltage fluctuation +/- 10%)
Frequency	50 to 60 Hz
Power	450 VA
Fuse	2 x T4 A (slow blow) 250 V

**Power Supply (24 Vdc) for IC Controller:**

Input voltage	24 Vdc
Max input power	200 W
Stand-by power	10 W
Max operating power	150 W with water or air cooling

**Protection Fuse** 8 A

**Max Operating Altitude** 3000 m

**USB Communication** as per USB 1.1

**Power Cable**

Required motor input voltage is 24V +/- 10%; please dimension power cable to guarantee the minimum voltage level. I.e. for AWG 20 resistance is 33,31 mOhm/m; so for a cable of 6 meters and maximum current (7.5A) the voltage lost is 1.5V.

**Compliance With:**

- EN 61010-1
- EN 61326-1
- EN 1012-2
- EN 12100
- EN 50581
- Machinery Directive 2006/42/EC
- Electromagnetic Compatibility Directive 2014/30/EU
- Directive 2011/65/EU

# Agilent Turbo Pump Models



TwisTorr 305 FSQ

TwisTorr 305-ICQ

## TwisTorr 305 FSQ and TwisTorr 305-ICQ

### Technical Specifications

<b>Pumping Speed</b>	ISO 100 K	
H <sub>2</sub>	220 L/s	
He	255 L/s	
N <sub>2</sub>	250 L/s	
<b>Max Gas Flow Rate</b>	TwisTorr 305 FSQ	TwisTorr 305-ICQ
H <sub>2</sub>	500 SCCM	500 SCCM
He	500 SCCM	500 SCCM
N <sub>2</sub>	450 SCCM	380 SCCM
Ar	100 SCCM	
<b>Compression Ratio</b>	ISO 100	
H <sub>2</sub>	2 x 10 <sup>4</sup>	
He	1 x 10 <sup>5</sup>	
N <sub>2</sub>	2 x 10 <sup>8</sup>	
<b>Max Foreline Pressure Tolerance</b>	16 mbar	
N <sub>2</sub>	16 mbar	
<b>Note:</b>	Foreline tolerance defined as the pressure at which the turbo pump still produces a compression of 100. For continuous operation, water cooling is recommended (water temperature between 15 and 20 °C).	

<b>Base Pressure with Recommended Forepump</b>	<1 x 10 <sup>-10</sup> mbar (<1 x 10 <sup>-10</sup> Torr)
--	--

According to standard DIN 28 428, the base pressure is that measured in a leak-free test dome, 48 hours after the completion of test dome bake-out, with a turbo pump fitted with a ConFlat flange and using the recommended pre-vacuum pump.

<b>Inlet Flange</b>	TwisTorr 305 FSQ and 305-ICQ: ISO 100, CFF 6", ISO 160, CFF 8"
---------------------	---

<b>Foreline Flange</b>	KF16 NW (KF25 - optional)
------------------------	---------------------------

<b>Max Rotation Speed</b>	60.600 rpm (1010 Hz driving frequency)
---------------------------	--

<b>Start-Up Time</b>	< 3 minutes (longer when soft start is used)
----------------------	--

<b>Recommended Forepump</b>	Dry pumps: IDP-3 (no gas flow), IDP-7, IDP-10, Mechanical: DS102, DS302
-----------------------------	---

<b>Operating Position</b>	Any
---------------------------	-----

<b>Oper. Ambient Temperature</b>	+5 to +35 °C
----------------------------------	--------------

<b>Bakeout Temperature</b>	ISO flange: 75 °C at inlet flange max CFF flange: 100 °C at inlet flange max  Note: Measure a point close to the sealing element.
----------------------------	--

<b>Lubricant</b>	Permanent lubrication
------------------	-----------------------

<b>Cooling Requirements:</b>	
<b>Air Cooling</b>	Natural convection (only with no gas load) Forced air (5 - 35 °C ambient temperature)

<b>Water Cooling</b>	Minimum flow: 50 L/h (0.22 GPM) Maximum flow: 150 L/h (0.66 GPM) Temperature: +15 to +30 °C Max pressure: 5 bar (75 psi)
----------------------	---

<b>Noise Pressure Level (at 1m at full speed)</b>	41 dB(A)
---	----------

Note: mean values based on a significative sample (Ar and N<sub>2</sub> compression ratio estimated); standard deviation per test: pumping speed: below ± 7%; noise pressure level: ± 10% (only pump).

<b>Installation Category</b>	II
------------------------------	----

<b>Pollution Degree</b>	2
-------------------------	---

<b>Storage Temperature</b>	-40 to +70 °C
----------------------------	---------------

<b>Weight kg (lbs)</b>	<b>305 FSQ</b>	<b>305-ICQ</b>
Pump ISO 100 K	5.84 (12.87)	5.74 (12.65)
Pump CFF 6"	8.16 (17.98)	8.06 (17.76)
Pump ISO 160 K	6.28 (13.84)	6.18 (13.62)
Pump CFF 8"	10.43 (22.99)	10.33 (22.77)

**Remote Controller:**

Voltage	100 - 240 Vac (voltage fluctuation +/- 10%)
Frequency	50 to 60 Hz
Power	450 VA
Fuse	2 x T4 A (slow blow) 250 V

**Power Supply (24 Vdc) for IC Controller:**

Max input power:	300 VA
Pump stand-by average power:	10 W
Pump max operating power:	150 W

**Max Operating Altitude** 3000 m

**Max Magnetic Field**

- 50 Gauss (5 mT) in the transversal direction
- 100 Gauss (10 mT) in the axial direction

**Compliance With:**

- EN 61010-1
- EN 61326-1
- EN 1012-2
- EN 12100
- EN 50581
- Machinery Directive 2006/42/EC
- Electromagnetic Compatibility Directive 2014/30/EU
- Directive 2011/65/EU

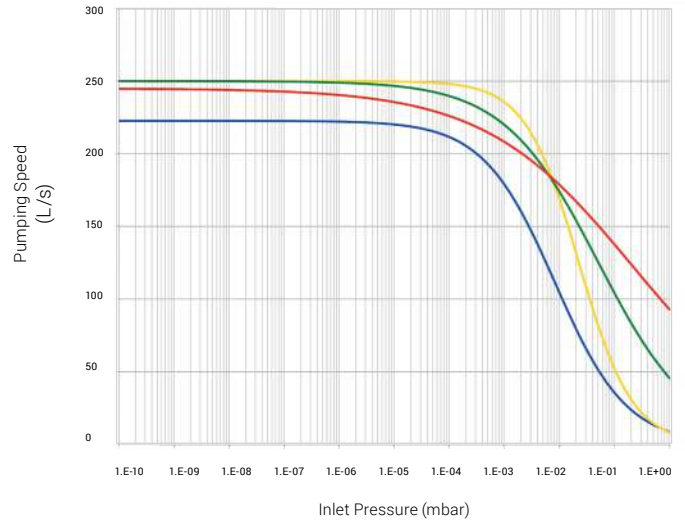

TwisTorr 305 FSQ, TwisTorr 305-ICQ Pumping speed

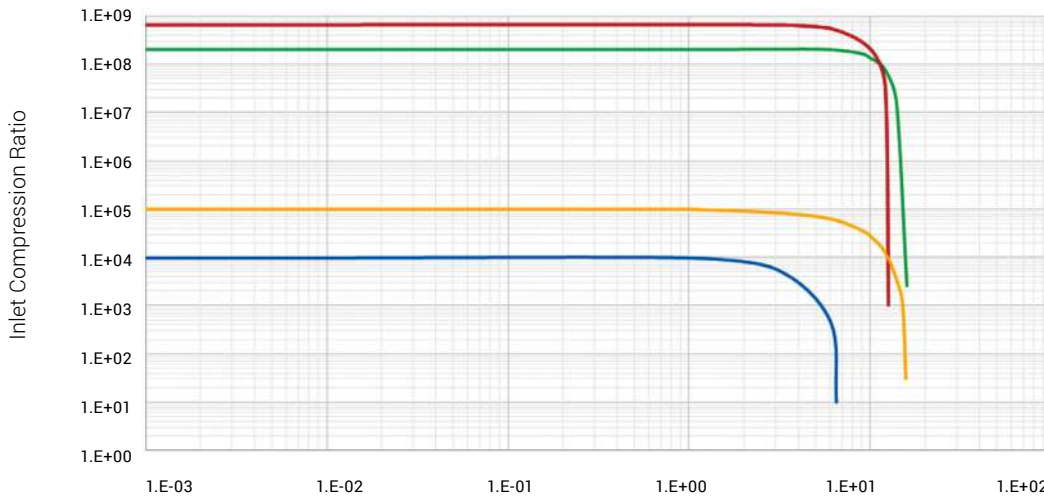

TwisTorr 305 FSQ, TwisTorr 305-ICQ Compression ratio

— Hydrogen    — Nitrogen  
— Helium      — Argon

Foreline Pressure (mbar)

# Agilent Turbo Pump Models

## Ordering Information

Pumps	Cooling	Flange	Part Number
TwisTorr 305-IC, 485A	Air	ISO 100 K	X3513-64000
TwisTorr 305-IC, 485A	Air	CFF 6"	X3513-64001
TwisTorr 305 IC, 485A	Air	ISO 160 K	X3513-64002
TwisTorr 305 IC, 485A	Air	CFF 8"	X3513-64003
TwisTorr 305 IC, 485A	Water	ISO 100 K	X3513-64004
TwisTorr 305 IC, 485A	Water	CFF 6"	X3513-64005
TwisTorr 305 IC, 485A	Water	ISO 160 K	X3513-64006
TwisTorr 305 IC, 485A	Water	CFF 8"	X3513-64007
TwisTorr 305-IC, 485P	Air	ISO 100 K	X3513-64016
TwisTorr 305-IC, 485P	Air	CFF 6"	X3513-64017
TwisTorr 305-IC, 485P	Air	ISO 160 K	X3513-64018
TwisTorr 305-IC, 485P	Air	CFF 8"	X3513-64019
TwisTorr 305-IC, 485P	Water	ISO 100 K	X3513-64020
TwisTorr 305-IC, 485P	Water	CFF 6"	X3513-64021
TwisTorr 305-IC, 485P	Water	ISO 160 K	X3513-64022
TwisTorr 305-IC, 485P	Water	CFF 8"	X3513-64023
TwisTorr 305-IC, 232	Air	ISO 100 K	X3513-64024
TwisTorr 305-IC, 232	Air	CFF 6"	X3513-64025
TwisTorr 305-IC, 232	Air	ISO 160 K	X3513-64026
TwisTorr 305-IC, 232	Air	CFF 8"	X3513-64027
TwisTorr 305-IC, 232	Water	ISO 100 K	X3513-64028
TwisTorr 305-IC, 232	Water	CFF 6"	X3513-64029
TwisTorr 305-IC, 232	Water	ISO 160 K	X3513-64030
TwisTorr 305-IC, 232	Water	CFF 8"	X3513-64031
TwisTorr 305 FS	Air	ISO 100 K	X3513-64008
TwisTorr 305 FS	Air	CFF 6"	X3513-64009
TwisTorr 305 FS	Air	ISO 160 K	X3513-64010
TwisTorr 305 FS	Air	CFF 8"	X3513-64011
TwisTorr 305 FS	Water	ISO 100 K	X3513-64012
TwisTorr 305 FS	Water	CFF 6"	X3513-64013
TwisTorr 305 FS	Water	ISO 160 K	X3513-64014
TwisTorr 305 FS	Water	CFF 8"	X3513-64015
Controllers			
TwisTorr 305 FS Remote Controller 232-485			X3506-64130
TwisTorr 305 FS Remote Controller Profibus			X3506-64131
Cables			
Mains cable NEMA plug, 3 m long *			9699958
Mains cable European plug, 3 m long *			9699957
Mains cable China plug, 3 m long *			8121-0723
5 m Turbopump Extension Cable *			969-9942M007
10 m Turbopump Extension Cable *			969-9942M006
15 m Turbopump Extension Cable *			969-9942M005
20 m Turbopump Extension Cable *			969-9942M004
50 m Turbopump Extension Cable *			969-9942M015
5 m Turbopump Fan Extension Cable **			9699949

Inlet Screens	Part Number
Inlet Screen ISO 100 K	X3500-68000
Inlet Screen CFF 6"	9699302
Inlet Screen ISO 160 K	X3500-68001
Inlet Screen CFF 8"	9699304
Cooling	
Water Cooling Kit	9699337
Metric Water Kit 4 x 6 mm	9699347
Air cooling kit for TwisTorr 305-IC ** (Kit X3514-68001 is required)	X3500-68010
Air cooling kit for TwisTorr 305 Remote controller *	X3500-68011
Fan extension cable for Remote Controller *	9699940
5 m Vent Valve Extension cable *	9699941
Vibration isolators	
Vibration isolator ISO 100 K	9699344
Vibration isolator CFF 6"	9699334
Vibration isolator ISO 160 K	9699345
Vibration isolator CFF 8"	9699335
Venting	
Vent Valve N.O. 1, 2 mm for TwisTorr 305-IC ** (Kit X3514-68001 is required)	9699834
Vent Valve N.O. 0,5 mm for TwisTorr 305-IC ** (Kit X3514-68001 is required)	9699834M006
DB15 Mating Connector not wired 7.5A **	X3514-68000
TwisTorr 305-IC Fan/Vent Adapter kit **	X3514-68001
Vent Valve N.O. 0,5 mm Orifice *	9699844
Vent Valve N.O. 1.2 mm Orifice *	9699845
Vent Valve N.C. 1.2 mm Orifice *	9699846
Vent Valve N.C. 0,5 mm Orifice *	9699847
Purge	
Purge valve 10 SCCM NW16KF - M12	9699239
Purge valve 10 SCCM ¼ Swagelock - M12	9699240
Purge valve 20 SCCM NW16KF - M12	9699241
Purge valve 20 SCCM ¼ Swagelock - M12	9699242
Purge valve 10 SCCM ¼ Swagelock - ¼ Swagelock	9699232
Purge valve 20 SCCM ¼ Swagelock - ¼ Swagelock	9699236
Other accessories	
Serial to Bluetooth adapter (necessary for App) *	X3514-68003
KF25 Foreline flange	X3513-68000

\* For TwisTorr 305 FS

\*\* For TwisTorr 305-IC

## Ordering Information

Pumps	Cooling	Flange	Part Number
TwisTorr 305 FSQ	Air/Water	ISO100K	X3513-64068
TwisTorr 305-ICQ, 485A	Water	ISO100K	X3513-64060
TwisTorr 305-ICQ, 485A	Air	ISO100K	X3513-64061
TwisTorr 305-ICQ, 485A	Water	CFF6"	X3513-64062
TwisTorr 305-ICQ, 485A	Air	CFF6"	X3513-64063
TwisTorr 305-ICQ, 485A	Water	ISO160K	X3513-64064
TwisTorr 305-ICQ, 485A	Water	CFF8"	X3513-64065
<b>Controllers</b>			
TwisTorr 305 FS Remote Controller 232-485			X3506-64130
TwisTorr 305 FS Remote Controller Profibus			X3506-64131
<b>Cables</b>			
Mains cable NEMA plug, 3 m long *			9699958
Mains cable European plug, 3 m long *			9699957
Mains cable China plug, 3 m long *8			121-0723
5 m Turbopump Extension Cable *			969-9942M007
10 m Turbopump Extension Cable *			969-9942M006
15 m Turbopump Extension Cable *			969-9942M005
20 m Turbopump Extension Cable *			969-9942M004
50 m Turbopump Extension Cable *			969-9942M015
5 m Turbopump Fan Extension Cable **			9699949
<b>Inlet Screens</b>			<b>Part Number</b>
Inlet Screen ISO 100 K			X3500-68000
Inlet Screen CFF 6"			9699302
Inlet Screen ISO 160 K			X3500-68001
Inlet Screen CFF 8"			9699304
<b>Cooling</b>			
Water Cooling Kit			9699337
Metric Water Kit 4 x 6 mm			9699347

\* For TwisTorr 305 FSQ

\*\* For TwisTorr 305-ICQ

Air cooling kit for TwisTorr 305-IC models ** (Kit X3514-68001 is required)	X3500-68010
Air cooling kit for TwisTorr 305 Remote controller *	X3500-68011
Fan extension cable for Remote Controller *	9699940
5 m Vent Valve Extension cable *	9699941
<b>Vibration isolators</b>	
Vibration isolator ISO 100 K	9699344
Vibration isolator CFF 6"	9699334
Vibration isolator ISO 160 K	9699345
Vibration isolator CFF 8"	9699335
<b>Venting</b>	
Vent Valve N.O. 1, 2 mm for TwisTorr 305-IC models ** (Kit X3514-68001 is required)	9699834
Vent Valve N.O. 0,5 mm for TwisTorr 305-IC models ** (Kit X3514-68001 is required)	9699834M006
DB15 Mating Connector not wired 7.5A **	X3514-68000
TwisTorr 305-IC Fan/Vent Adapter kit **	X3514-68001
Vent Valve N.O. 0,5 mm Orifice *	9699844
Vent Valve N.O. 1.2 mm Orifice *	9699845
Vent Valve N.C. 1.2 mm Orifice *	9699846
Vent Valve N.C. 0,5 mm Orifice *	9699847
<b>Purge</b>	
Purge valve 10 SCCM NW16KF - M12	9699239
Purge valve 10 SCCM ¼ Swagelock - M12	9699240
Purge valve 20 SCCM NW16KF - M12	9699241
Purge valve 20 SCCM ¼ Swagelock - M12	9699242
Purge valve 10 SCCM ¼ Swagelock - ¼ Swagelock	9699232
Purge valve 20 SCCM ¼ Swagelock - ¼ Swagelock	9699236
<b>Other accessories</b>	
Serial to Bluetooth adapter (necessary for App) *	X3514-68003
KF25 Foreline flange	X3513-68000

# Agilent Turbo Pump Models



## TwisTorr 404 FS

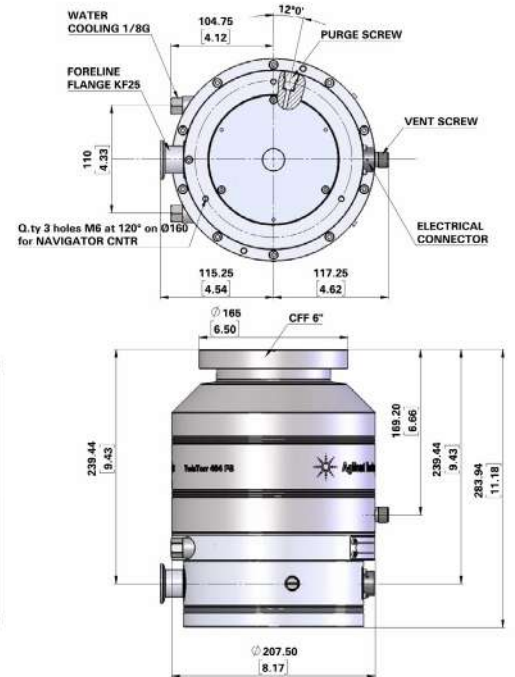
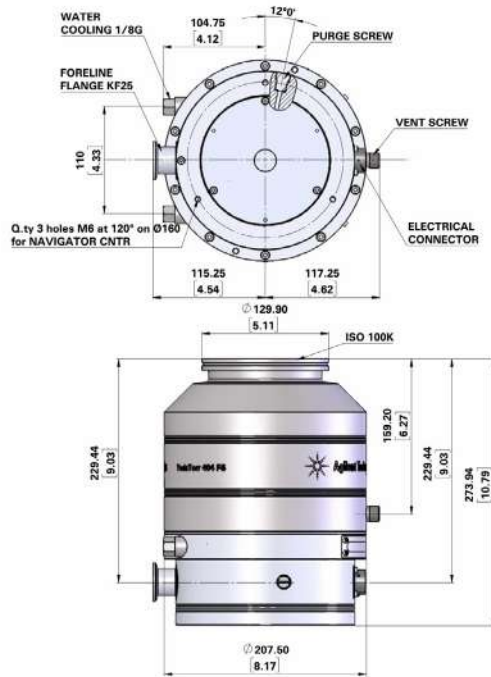

Dimensions: millimeters [inches]

### Technical Specification

Pumping Speed	ISO100K-F	CFF6
N <sub>2</sub>	355 l/s	
He	470 l/s	
H <sub>2</sub>	445 l/s	
Ar	320 l/s	
Max Gas Throughput(*)	Air cooling (25 °C Air temperature)	Water cooling (15 °C water temperature / 25 °C room temperature)
N <sub>2</sub>	4.3 mbarL/s 255 SCCM	6.2 mbarL/s 367 SCCM
He	7.9 mbarL/s 467 SCCM	10.4 mbarL/s 615 SCCM
Ar	1.5 mbarL/s 89 SCCM	3.3 mbarL/s 195 SCCM
Compression Ratio and Foreline Tolerance		
N <sub>2</sub>	>1 x 10 <sup>11</sup>	>10 mbar
He	2 x 10 <sup>9</sup>	>10 mbar
H <sub>2</sub>	3 x 10 <sup>6</sup>	>4 mbar
Ar	>1 x 10 <sup>11</sup>	>8.5 mbar
(*) Foreline Tolerance defined as the pressure at which the turbopump still produce a compression of 100 and estimated in water cooling mode.		
Inlet Flange	ISO 100K, ISO 100F, CFF 6"	
Foreline Flange	NW25 (NW16 as optional accessory)	
Rotational Speed	Auto setting from 40.800 RPM to 49.500 RPM	
Start-Up Time	< 5 minutes	

Recommended Forepump	Mechanical: Agilent DS 302, TS 300 Dry pump: Agilent IDP-10, IDP-15	
Operating Position	Any	
Oper. Ambient Temperature	+5 to +35 °C	
Rel. Humidity of Air	0 to 90% (not condensing)	
Bakeout Temperature	ISO pump: 80 °C at inlet flange CFF pump: 120 °C at inlet flange	
Lubricant	Permanent grease lubrication	
Cooling Requirements		
Air Cooling	Air temperature from +5 to 35 °C	
Water Cooling	Water temperature from +15 to +25 °C Water flow min. 100l/h	
Noise Pressure Level (at 1m at full speed)	43dB(A)	
Storage Temperature	-40 to +70 °C	
Max Altitude	3000 m	
Weight kg (lbs)	ISO100K ISO100F CFF 6"	20.6 Kg / 45.3 lbs. 22.1 Kg / 48.6 lbs. 22 Kg / 48.4 lbs.
Conformity to Norms		
EMC (Control Units)	61326-1	
Safety (CE/CSA)	61010-1	
Machinery Directive	DIR 2006/42/CE	
Low Voltage Directive	DIR 2014/35/EU	
EMC Directive (Control Units)	DIR 2014/30/EU	
ROHS	DIR 2011/65/EU	

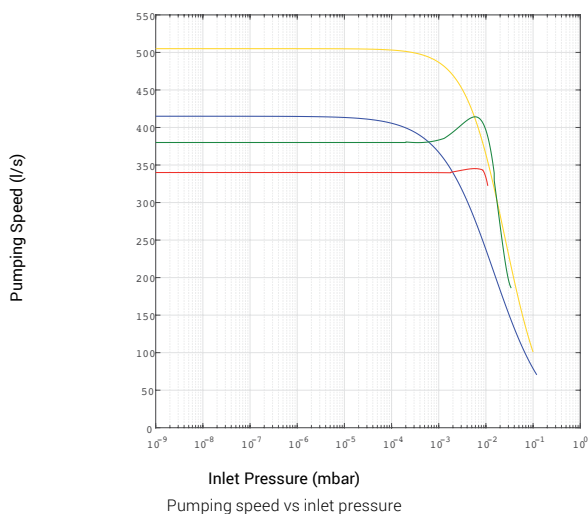

— Hydrogen  
— Helium  
— Nitrogen  
— Argon

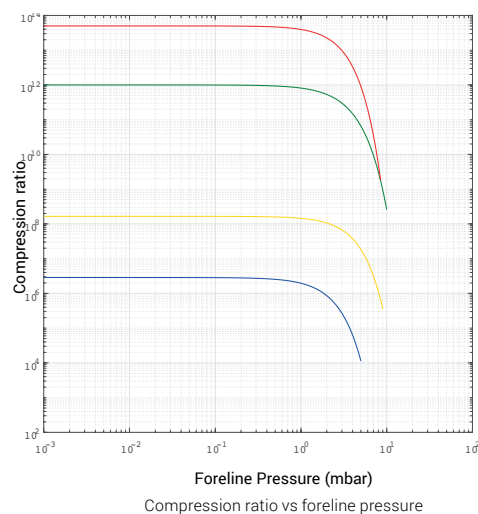

## Ordering Information

Pumps	Part Number
TwisTorr 404 FS ISO100K KF25 water cooling	X3511-64019
TwisTorr 404 FS ISO100F KF25 water cooling	X3511-64020
TwisTorr 404 FS CFF6" KF25 water cooling	X3511-64021

Controllers	Part Number
TwisTorr Medium-TMP rack controller	X3501-64016
TwisTorr Medium-TMP on board controller	X3512-64016

Cables	Part Number
Mains cable NEMA plug 3 m long	9699958
Mains cable EU plug 3 m long	9699957
Mains cable UK plug 2.5 m long	X3501-68005
Mains cable China plug 3 m long	X1699-64144
Replace with: RS232 serial cable and A-PLUS software, 3 m long	9699883

Extension cables*	Part Number	Length
	9699948	(3 m)
	9699948M001	(5 m)
	9699948M003	(10 m)
	9699948M004	(15 m)
	9699948M002	(20 m)
	9699948M005	(30 m)
	9699948M009	(75 m)
	9699948M010	(100 m)

Inlet Screen	Part Number
Inlet screen iso100/cff6	9699302

Cooling	Part Number
Medium-TMP air cooling kit for rack controller	X3501-68001
Medium-TMP air cooling kit for on board controller	9699297
Plastic water cooling kit	9699347
Metal water cooling kit	9699337
Air cooling kit extension cable 5m	x3501-68101
Air cooling kit extension cable 10m	x3501-68051
Air cooling kit extension cable 15m	X3501-68061
Air cooling kit extension cable 20m	X3501-68021

Air cooling kit extension cable 30m	X3501-68011
Air cooling kit extension cable 50m	X3501-68071
Air cooling kit extension cable 75m	X3501-68081
Air cooling kit extension cable 100m	X3501-68091

Venting	Part Number
Vent valve kit, normally open, with 5 m cable, for pumps driven by rack controllers	X3501-68002
Vent valve kit, normally closed, with 5 m cable, for pumps driven by rack controllers	X3501-68022
Vent valve kit, normally open, with 0.6 m cable, for pumps driven by onboard controllers	9699834
Vent flange, NW 10 KF / M8	9699108
	X3501-68004 (5 m)
	X3501-68054 (10 m)
	X3501-68064 (15 m)
Vent valve rack extension cable	X3501-68074 (20 m)
	X3501-68084 (30 m)
	X3501-68034 (50 m)
	X3501-68094 (75 m)
	X3501-68104 (100 m)

Purge	Part Number
Purge valve 10 SCCM NW16KF - M12	9699239
Purge 10SCCM M12-1/4 Swagelok	9699240
Purge 20SCCM M12-NW16KF	9699241
Purge valve 20 SCCM ¼ Swagelok - M12	9699242
Spare purge screw	X3502-68004

Mounting	Part Number
Change description of X3511-68003 to: Medium TMP onboard controller side mounting bracket	X3511-68003
Medium-TMP KF16 foreline flange	X3511-68004
Medium-TMP KF25 foreline flange	X3511-68001
Medium-TMP KF40 foreline flange	X3511-68002

\*For a complete list of available extension cables, see the [Extension Cables for Turbo Pumps dedicated page](#) on Agilent.com.

# Agilent Turbo Pump Models



## Turbo V-551 Navigator

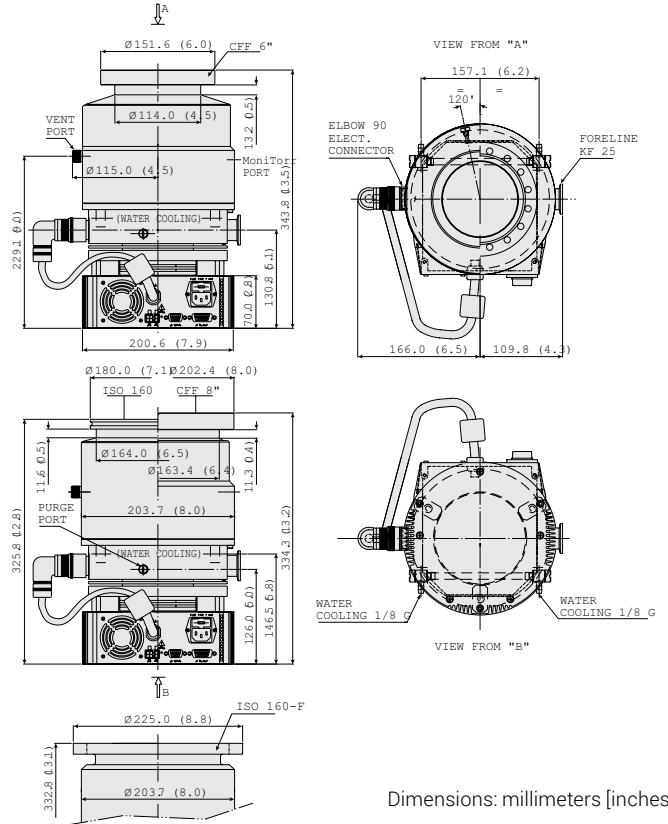

Dimensions: millimeters [inches]

### Technical Specification

<b>Pumping Speed (with inlet screen)</b>				<b>Operating Position</b>	Any	
CFF 6"	N <sub>2</sub> : 350 l/s	He: 450 l/s	H <sub>2</sub> : 450 l/s	<b>Cooling Requirements</b>	Natural air convection Water optional (use water with electrical conductivity ≤ 500 µS/cm)	
CFF 8" or ISO 160	N <sub>2</sub> : 550 l/s	He: 600 l/s	H <sub>2</sub> : 510 l/s		<b>Bakeout Temperature</b>	120 °C at inlet flange max. (CF flange) 80 °C at inlet flange max. (ISO flange)
<b>Compression Ratio</b>		N <sub>2</sub> : 1x10 <sup>9</sup>	He: 1x10 <sup>7</sup>	H <sub>2</sub> : 1x10 <sup>6</sup>	<b>Vibration Level (displacement)</b>	<0.01 µm at inlet flange
<b>Base Pressure* (with minimum recommended forepump)</b>		<1 x 10 <sup>-10</sup> mbar (< 1 x 10 <sup>-10</sup> Torr)			<b>Weight kg (lbs)</b>	ISO flange 19.4 (43.0) CFF flange 23.4 (51.6) CFF and ISO bolted flange 23.4 (51.6)
* According to PNEUROP 5608.						
<b>Inlet Flange</b>	CFF 6": ISO 160 CFF 8": ISO 160-F bolted					
<b>Foreline Flange</b>	KF 25					
<b>Rotational Speed</b>	42.000 rpm					
<b>Start-Up Time</b>	<5 minutes					
<b>Recommended Forepump</b>	Mechanical: Agilent DS 302 Dry scroll: Agilent TS300, IDP-15					
<b>SEM version available on request</b>						

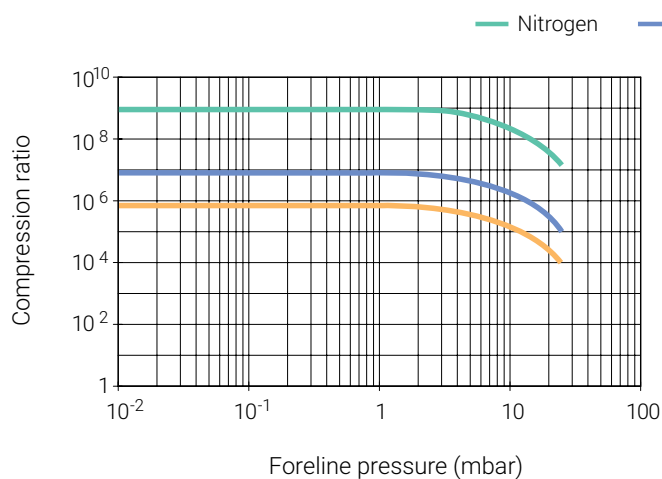

Compression ratio vs foreline pressure

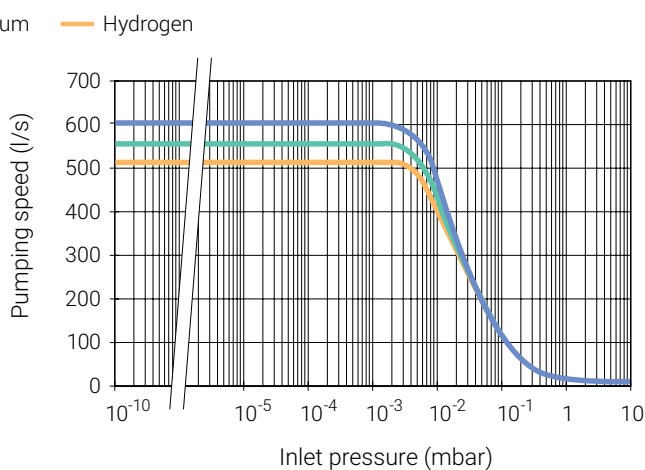

Pumping speed vs inlet pressure

## Ordering Information

Description	Part Number
<b>Pumps</b>	
Turbo-V 551 Navigator pump, ISO 160 flange	9698922
Turbo-V 551 Navigator pump, ISO 160-F bolted flange	9698944
Turbo-V 551 Navigator pump, 6" CFF flange	9698925
Turbo-V 551 Navigator pump, 8" CFF flange	9698923
<b>Controllers</b>	
Turbo-V 551 Navigator controller 120/220 V - 50/60 Hz	9698976
Turbo-V 551 Rack controller, 100-240 V	X3501-64001
<b>Accessories</b>	
Mains cable NEMA plug, 3 m long	9699958
Mains cable European plug, 3 m long	9699957
Mains cable UK plug 2.5 m long	X3501-68005
Mains cable China plug 3 m long	X1699-64144
RS232 serial cable and A-PLUS software, 3 m long	9699883
Extension cable	9699948 (3 m)
	9699948M001 (5 m)
	9699948M002 (20 m)
	9699948M003 (10 m)
	9699948M004 (15 m)
	9699948M005 (30 m)
	9699948M011 (65 m)
	9699948M009 (75 m)
	9699948M010 (100 m)
	Inlet screen DN 100
Inlet screen DN 160	9699304

Water cooling kit	9699337
Plastic water cooling kit	9699347
Air cooling kit for use with Navigator controller	9699339
Air cooling kit for use with standard rack controller, 24 V	X3501-68001
Bracket for Navigator controller side mouting	9699349
Vibration damper CFF 6"	9699334
Vibration damper CFF 8"	9699335
Vent valve adapter, NW10 to M8 male threads	9699108
Vent valve kit, normally open, with 5 m cable, for pumps driven by rack controllers	X3501-68002
Vent valve kit, normally open, with 0.6 m cable, for pumps driven by onboard controllers	9699834
Purge valve 10 SCCM NW16KF - M12	9699239
Purge valve 10 SCCM ¼ Swagelok - M12	9699240



## Turbo-V 701 Navigator

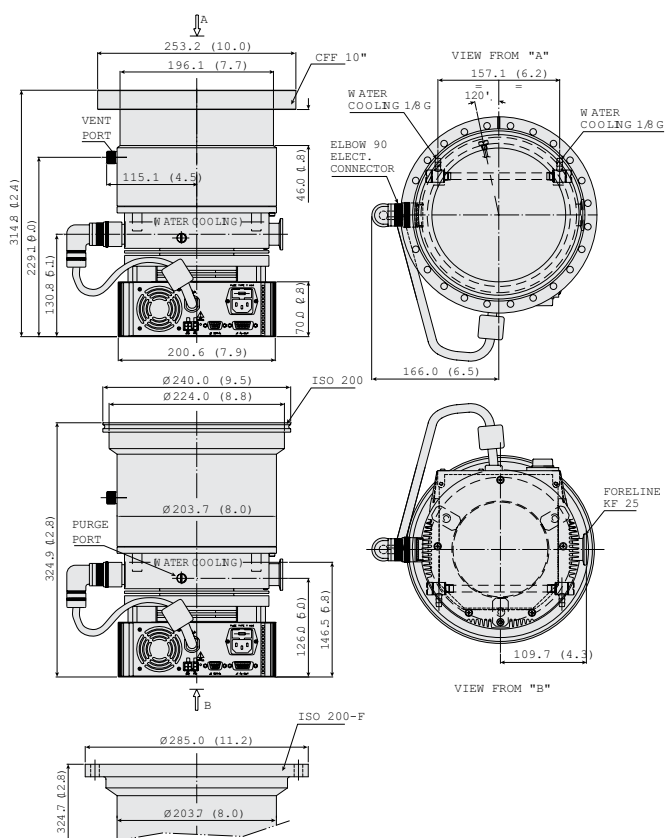

Dimensions: millimeters [inches]

### Technical Specification

<b>Pumping Speed</b> (with inlet screen) CFF 10" or ISO 200	N <sub>2</sub> : 690 l/s	He: 620 l/s	H <sub>2</sub> : 510 l/s
<b>Compression Ratio</b>	N <sub>2</sub> : 1 x 10 <sup>9</sup>	He: 1 x 10 <sup>7</sup>	H <sub>2</sub> : 1 x 10 <sup>6</sup>
<b>Base Pressure*</b> (with minimum recommended forepump)	<1 x 10 <sup>-10</sup> mbar (< 1 x 10 <sup>-10</sup> Torr)		
<b>Inlet Flange</b>	CFF 10"	ISO 200	ISO 200-F bolted
<b>Foreline Flange</b>	KF 25		
<b>Rotational Speed</b>	42,000 rpm		
<b>Start-Up Time</b>	<5 minutes		
<b>Recommended Forepump</b>	Mechanical: Agilent DS 402 Dry scroll: Agilent TS300, IDP-15		
<b>Operating Position</b>	Any		

### Cooling Requirements

Natural air convection  
Water optional  
(use water with electrical  
conductivity ≤ 500 µS/cm)

### Bakeout Temperature

120 °C at inlet flange max.  
(CF flange)  
  
80 °C at inlet flange max.  
(ISO flange)

### Vibration Level (displacement)

<0.01 µm at inlet flange

### Weight kg (lbs)

ISO flange 19.4 (43.0)  
CFF flange 25.5 (54.2)  
CFF and ISO bolted flange 25.5 (54.2)

\*According to PNEUROP 5608.

SEM version available on request

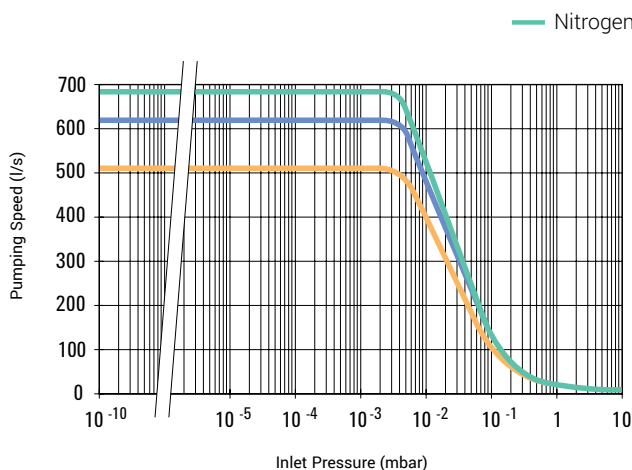

Pumping speed vs inlet pressure

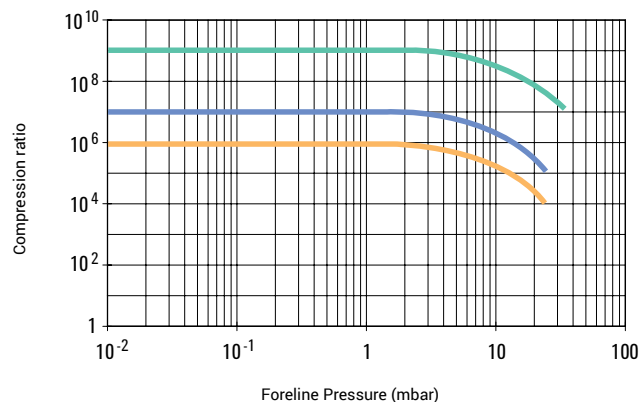

Compression ratio vs foreline pressure

## Ordering Information

Description	Part Number
<b>Pumps</b>	
Turbo-V 701 Navigator pump, ISO 200-K	9698926
Turbo-V 701 Navigator pump, 10" CFF	9698927
<b>Controllers</b>	
Turbo-V 701 Navigator controller 120/220 V - 50/60 Hz	9698977
Turbo-V 701 rack controller, 120/220 V	X3501-64002
<b>Accessories</b>	
Mains cable NEMA plug, 3 m long	9699958
Mains cable European plug, 3 m long	9699957
Mains cable UK plug, 2.5 m long	X3501-68005
Mains cable China plug, 3 m long	X1699-64144
RS232 serial cable and A-PLUS software, 3 m long	9699883
Extension cable	9699948 (3 m)
	9699948M001 (5 m)
	9699948M002 (20 m)
	9699948M003 (10 m)
	9699948M004 (15 m)
	9699948M005 (30 m)
	9699948M009 (75 m)
	9699948M010 (100 m)
	9699948M011 (65 m)
Inlet screen DN 200	9699316
Vibration damper, ISO 200	9699346
Vibration damper, CFF 10"	9699336
Water cooling kit	9699337
Plastic water cooling kit	9699347
Air cooling kit for use with Navigator controller	9699339

Air cooling kit for use with standard rack controller, 24 V	X3501-68001
Bracket for Navigator controller side mounting	9699349
Vent valve adapter, NW10 to M8 male threads	9699108
Vent valve kit, normally open, with 5 m cable, for pumps driven by rack controllers	X3501-68002
Vent valve kit, normally open, with 0.6 m cable, for pumps driven by onboard controllers	9699834
Purge valve 10 SCCM NW16KF – M12	9699239
Purge valve 10 SCCM ¼ Swagelok – M12	9699240

# Agilent Turbo Pump Models



## TwisTorr 704 FS

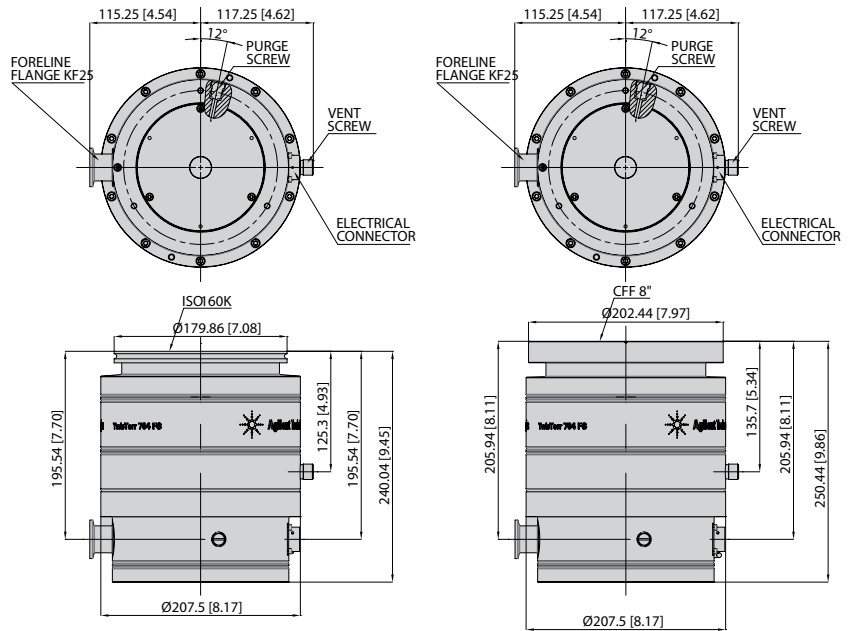

Dimensions: millimeters [inches]

### Technical Specification

<b>Pumping Speed</b>	ISO 160 / CFF 8"	
N <sub>2</sub>	660 L/s	
He	640 L/s	
H <sub>2</sub>	480 L/s	
Ar	625 L/s	
<b>Gas throughput at Full Rotational Speed (with recomm. forepump)*</b>	Ambient temp. (25 °C)	Water temperature. (25 °C, 50 L/h)
<b>He</b>	7.9 mbarL/s 467 SCCM	10.4 mbarL/s 615 SCCM
<b>N<sub>2</sub></b>	4.3 mbarL/s 255 SCCM	6.2 mbarL/s 367 SCCM
<b>Ar</b>	1.5 mbarL/s 89 SCCM	3.3 mbarL/s 195 SCCM
(*) Backing pump 11.6 m <sup>3</sup> /hr		
<b>Compression Ratio and Foreline Tolerance*</b>		
N <sub>2</sub>	>1 x 10 <sup>11</sup>	10 mbar
He	2 x 10 <sup>9</sup>	10 mbar
H <sub>2</sub>	3 x 10 <sup>6</sup>	>4 mbar
Ar	> 1 x 10 <sup>11</sup>	8.5 mbar
(*) Foreline Tolerance defined as the pressure at which the turbopump still produce a compression of 100 and estimated in water cooling mode		
<b>Base Pressure with Recommended Forepump</b>	< 1 x 10 <sup>-10</sup> mbar (< 1 x 10 <sup>-10</sup> Torr)	
<b>Inlet Flange</b>	ISO 160K, ISO 160F, CFF 8"	
<b>Foreline Flange</b>	NW25 (NW40 as optional accessory)	
<b>Rotational Speed</b>	Auto setting from 40.800 RPM to 49.500 RPM	
<b>Start-Up Time</b>	< 5 minutes	

<b>Recommended Forepump</b>	Mechanical: Agilent DS 302, TS 300 Dry pump: Agilent IDP-10, IDP-15	
<b>Operating Position</b>	Any	
<b>Oper. Ambient Temperature</b>	+5 to +35 °C	
<b>Rel. Humidity of Air</b>	0 - 90 % (not condensing)	
<b>Bakeout Temp.</b>	ISO pump: 80 °C at inlet flange CFF pump: 120 °C at inlet flange	
<b>Lubricant</b>	Permanent grease lubrication	
<b>Cooling Requirements</b>		
Air Cooling	Air temperature from +5 to 35 °C	
Water Cooling	Water temperature from +15 to +25 °C Water flow min. 100l/h	
<b>Noise Pressure Level (at 1 m at full speed)</b>	43dB(A)	
<b>Storage Temperature</b>	-40 to +70 °C	
<b>Max Altitude</b>	3000 m	
<b>Weight kg (lbs)</b>	ISO160K	20.6 Kg / 45.3 lbs.
	ISO160F	22.6 Kg / 49.7 lbs.
	CFF 8"	22 Kg / 48.4 lbs.
<b>Conformity to Norms</b>		
EMC (Control Units)	61326-1	
Safety (CE/CSA)	61010-1	
Machinery Directive	DIR 2006/42/CE	
Low Voltage Directive	DIR 2014/35/EU	
EMC Directive (Control Units)	DIR 2014/30/EU	
ROHS	DIR 2011/65/EU	

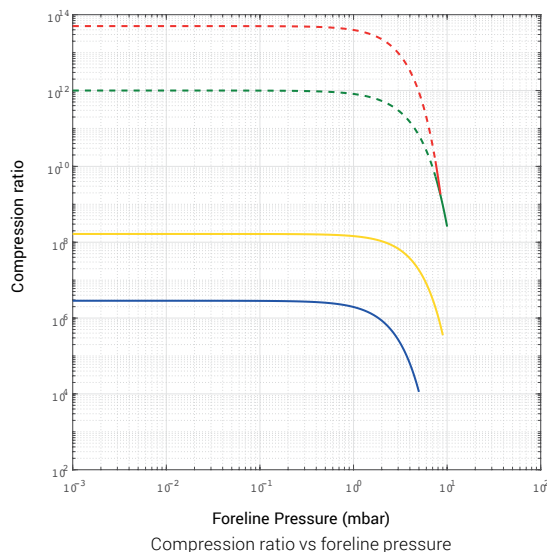
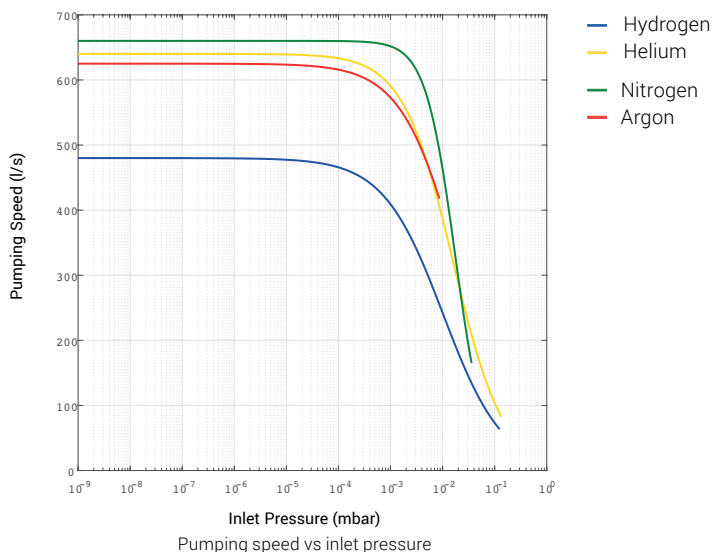

## Ordering Information

Pumps	Part Number
TwisTorr 704 FS ISO 160 K, KF 25 water cooling	X3511-64015
TwisTorr 704 FS ISO160F, KF25 water cooling	X3511-64016
TwisTorr 704 FS CFF8", KF25 water cooling	X3511-64017
TwisTorr 704 FS CFF8", Long-Neck KF25 water cooling	X3511-64018
TwisTorr 704 FS, One Speed, ISO 160 K, KF 25	X3511-64040
TwisTorr 704 FS, One Speed, ISO 160 F, KF 25	X3511-64041
TwisTorr 704 FS, One Speed, CFF 8", KF 25	X3511-64042
Controllers	
TwisTorr Medium-TMP rack controller	X3501-64016
TwisTorr Medium-TMP onboard controller	X3512-64016
TwisTorr Medium-TMP onboard controller, One Speed	X3512-64006
TwisTorr Medium-TMP onboard rugged controller	X3512-64026
Cables	
Mains cable NEMA plug 3 m long	9699958
Mains cable EU plug 3 m long	9699957
Mains cable UK plug 2.5 m long	X3501-68005
Mains cable China plug 3 m long	X1699-64144
RS232 serial cable and A-PLUS software, 3 m long	9699883
Extension cables*	9699948 (3 m)
	9699948M001 (5 m)
	9699948M003 (10 m)
	9699948M004 (15 m)
	9699948M002 (20 m)
	9699948M005 (30 m)
	9699948M009 (75 m)
	9699948M010 (100 m)
Inlet Screen	
ISO 160/ CFF 8	9699304
Mounting	
Medium TMP onboard controller side mounting bracket	X3511-68003
Medium-TMP KF16 foreline flange	X3511-68004
Medium-TMP KF25 foreline flange	X3511-68001

Medium-TMP KF40 foreline flange	X3511-68002
Cooling	
Medium-TMP air cooling kit for rack controller	X3501-68001
Medium-TMP air cooling kit for onboard controller	9699297
Plastic water cooling kit	9699347
Metal Water cooling Kit	9699337
Air cooling kit extension cable	X3501-68101 (5 m)
	X3501-68051 (10 m)
	X3501-68061 (15 m)
	X3501-68021 (20 m)
	X3501-68011 (30 m)
	X3501-68071 (50 m)
	X3501-68081 (75 m)
	X3501-68091 (100 m)
Venting	
Vent valve kit, normally open, with 5 m cable, for pumps driven by rack controllers	X3501-68002
Vent valve kit, normally closed, with 5 m cable, for pumps driven by rack controllers	X3501-68022
Vent valve kit, normally open, with 0.6 m cable, for pumps driven by onboard controllers	9699834
Vent flange, NW 10 KF / M8	9699108
Vent valve rack extension cable	X3501-68004 (5 m)
	X3501-68054 (10 m)
	X3501-68064 (15 m)
	X3501-68074 (20 m)
	X3501-68084 (30 m)
	X3501-68034 (50 m)
	X3501-68094 (75 m)
	X3501-68104 (100 m)
Purge	
Purge valve 10 SCCM NW16KF - M12	9699239
Purge 10SCCM M12-1/4 Swagelok	9699240
Purge 20SCCM M12-NW16KF	9699241
Purge valve 20 SCCM ¼ Swagelok - M12	9699242
Spare purge screw	X3502-68004

\*For a complete list of available extension cables, see the [Extension Cables for Turbo Pumps](#) dedicated page on Agilent.com.

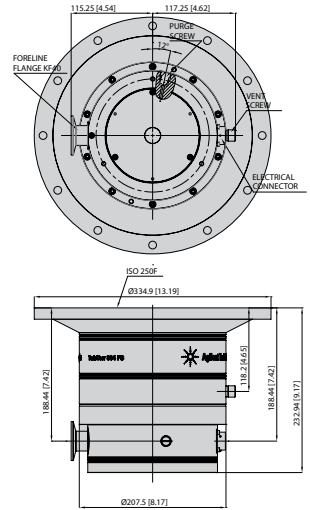
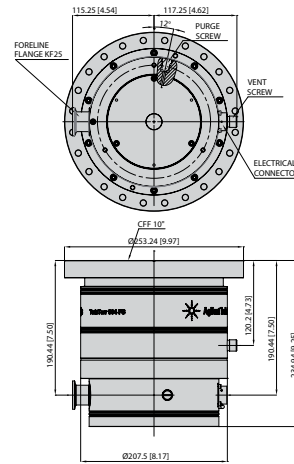
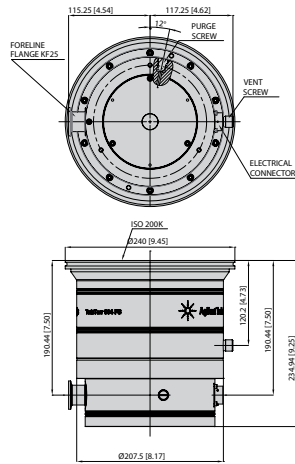

## TwisTorr 804 FS

Dimensions: millimeters [inches]

### Technical Specification

Pumping Speed	ISO200K	ISO250K	CFF10
	ISO200F	ISO250F	
N <sub>2</sub>		720 L/s	
He		660 L/s	
H <sub>2</sub>		485 L/s	
Ar		690 L/s	
Max Gas Throughput(*)	Air cooling (25 °C Air temperature)	Water cooling (15 °C water temperature /25 °C room temperature)	
N <sub>2</sub>	4.3 mbarL/s 255 SCCM	6.1 mbar L/s 367 SCCM	
He	7.9 mbar L/s 467 SCCM	10.4 mbar L/s 615 SCCM	
Ar	1.5 mbar L/s 89 SCCM	3.3 mbar L/s 195 SCCM	

(\*) Backing pump 11.6 m<sup>3</sup>/hr

#### Compression Ratio and Foreline Tolerance\*

N <sub>2</sub>	>1E+11	10 mbar
He	2E+08	10 mbar
H <sub>2</sub>	3E+06	>4 mbar
Ar	>1E+11	8.5 mbar

(\*) Foreline Tolerance defined as the pressure at which the turbopump still produce a compression of 100 and estimated in water cooling mode

Base Pressure with Recommended Forepump	< 1 x 10 <sup>-10</sup> mbar (< 1 x 10 <sup>-10</sup> Torr)
Inlet Flange	ISO 200K, ISO 200F, ISO 250K, ISO 250F, CFF 10"
Foreline Flange	NW25 or NW40
Rotational Speed	Auto setting from 40.800 RPM to 49'500 RPM
Start-Up Time	< 5 minutes

Recommended Forepump	Mechanical: Agilent DS 302, TS 300 Dry pump: Agilent IDP-10, IDP-15	
Operating Position	Any	
Oper. Ambient Temperature	+5 to +35 °C	
Rel. Humidity of Air	0 to 90% (not condensing)	
Bakeout Temperature	ISO pump: 80 °C at inlet flange CFF pump: 120 °C at inlet flange	
Lubricant	Permanent grease lubrication	
Cooling Requirements		
Air Cooling	Air temperature from +5 to 35 °C	
Water Cooling	Water temperature from +15 to +25 °C Water flow min. 100l/h	
Noise Pressure Level (at 1m at full speed)	43dB(A)	
Storage Temperature	-40 to +70 °C	
Max Altitude	3000 m	
Weight kg (lbs)	ISO200K	20.7 Kg / 45.5 lbs.
	ISO200F	23.6 Kg / 51.9 lbs.
	ISO250K	23.3 Kg / 51.2 lbs.
	ISO250F	27.6 Kg / 60.9 lbs.
	CFF 10"	22.1 Kg / 48.6 lbs.
Conformity to Norms		
EMC (Control Units)	61326-1	
Safety (CE/CSA)	61010-1	
Machinery Directive	DIR 2006/42/CE	
Low Voltage Directive	DIR 2014/35/EU	
EMC Directive (Control Units)	DIR 2014/30/EU	
ROHS	DIR 2011/65/EU	

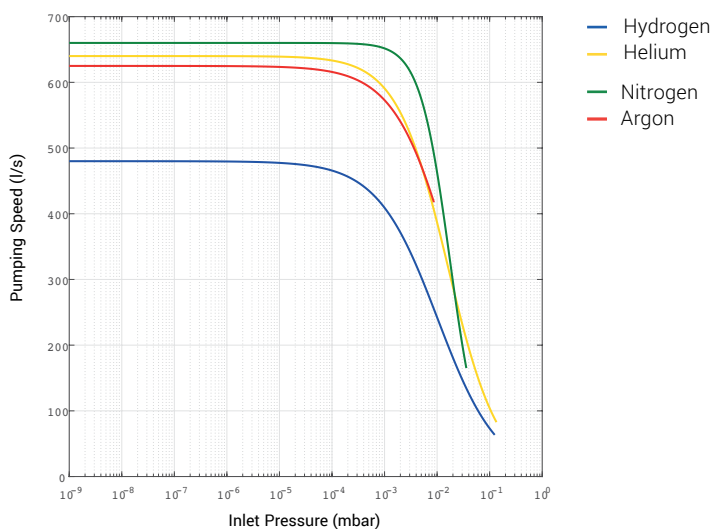

Pumping speed vs inlet pressure

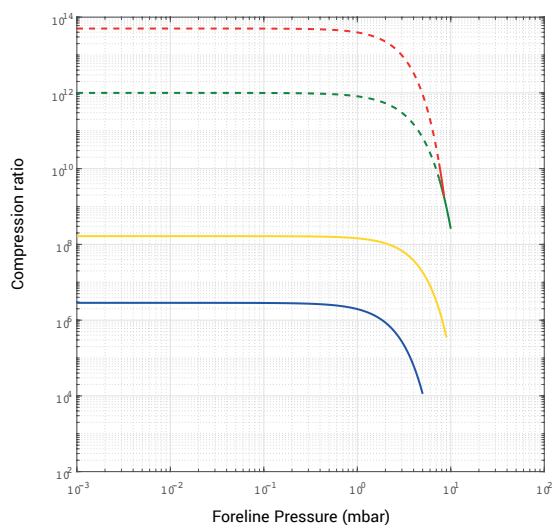

Compression ratio vs foreline pressure

## Ordering Information

Pumps	Part Number
TwisTorr 804 FS ISO200K KF25 air cooling	X3511-64007
TwisTorr 804 FS ISO200K KF40 air cooling	X3511-64008
TwisTorr 804 FS ISO200F KF25 air cooling	X3511-64009
TwisTorr 804 FS ISO200F KF40 air cooling	X3511-64010
TwisTorr 804 FS CFF10* KF25 air cooling	X3511-64011
TwisTorr 804 FS CFF10* KF40 air cooling	X3511-64012
TwisTorr 804 FS ISO250K KF40 air cooling	X3511-64013
TwisTorr 804 FS ISO250F KF40 air cooling	X3511-64014
TwisTorr 804 FS ISO200K KF25 water cooling	X3511-64022
TwisTorr 804 FS ISO200K KF40 water cooling	X3511-64023
TwisTorr 804 FS ISO200F KF25 water cooling	X3511-64024
TwisTorr 804 FS ISO200F KF40 water cooling	X3511-64025
TwisTorr 804 FS CFF10* KF25 water cooling	X3511-64026
TwisTorr 804 FS CFF10* KF40 water cooling	X3511-64027
TwisTorr 804 FS ISO250K KF40 water cooling	X3511-64028
TwisTorr 804 FS ISO250F KF40 water cooling	X3511-64029
Controllers	
TwisTorr Medium-TMP rack controller	X3501-64016
TwisTorr Medium-TMP on board controller	X3512-64016
Cables	
Mains cable NEMA plug 3 m long	9699958
Mains cable EU plug 3 m long	9699957
Mains cable UK plug 2.5 m long	X3501-68005
Mains cable China plug 3 m long	X1699-64144
RS232 serial cable and A-PLUS software, 3 m long	9699883
Extension cables*	
9699948 (3 m)	9699948M002 (20 m)
9699948M001 (5 m)	9699948M005 (30 m)
9699948M003 (10 m)	9699948M009 (75 m)
9699948M004 (15 m)	9699948M010 (100 m)
Inlet Screen	
ISO 200/ CFF 10	9699316
ISO 250	9699350
Cooling	
Medium-TMP air cooling kit for rack controller	X3501-68001

Medium-TMP Air Cooling Kit for on board Controller	9699297								
Plastic Water cooling Kit	9699347								
Metal Water cooling Kit	9699337								
Air cooling kit extension cable 5m	X3501-68101								
Air cooling kit extension cable 10m	X3501-68051								
Air cooling kit extension cable 15m	X3501-68061								
Air cooling kit extension cable 20m	X3501-68021								
Air cooling kit extension cable 30m	X3501-68011								
Air cooling kit extension cable 50m	X3501-68071								
Air cooling kit extension cable 75m	X3501-68081								
Air cooling kit extension cable 100m	X3501-68091								
Venting									
Vent valve kit, normally open, with 5 m cable, for pumps driven by rack controllers	X3501-68002								
Vent valve kit, normally closed, with 5 m cable, for pumps driven by rack controllers	X3501-68022								
Vent valve kit, normally open, with 0.6 m cable, for pumps driven by onboard controllers	9699834								
Vent flange, NW 10 KF / M8	9699108								
Vent valve rack extension cable	<table border="0"> <tr><td>X3501-68004 (5 m)</td><td>X3501-68004 (5 m)</td></tr> <tr><td>X3501-68054 (10 m)</td><td>X3501-68054 (10 m)</td></tr> <tr><td>X3501-68064 (15 m)</td><td>X3501-68064 (15 m)</td></tr> <tr><td>X3501-68074 (20 m)</td><td>X3501-68074 (20 m)</td></tr> </table>	X3501-68004 (5 m)	X3501-68004 (5 m)	X3501-68054 (10 m)	X3501-68054 (10 m)	X3501-68064 (15 m)	X3501-68064 (15 m)	X3501-68074 (20 m)	X3501-68074 (20 m)
X3501-68004 (5 m)	X3501-68004 (5 m)								
X3501-68054 (10 m)	X3501-68054 (10 m)								
X3501-68064 (15 m)	X3501-68064 (15 m)								
X3501-68074 (20 m)	X3501-68074 (20 m)								
Purge									
Purge valve 10 SCCM NW16KF - M12	9699239								
Purge 10SCCM M12-1/4 Swagelok	9699240								
Purge 20SCCM M12-NW16KF	9699241								
Purge valve 20 SCCM ¼ Swagelok - M12	9699242								
Spare purge screw	X3502-68004								
Mounting									
Medium TMP onboard controller side mounting bracket	X3511-68003								
Medium-TMP KF16 foreline flange	X3511-68004								
Medium-TMP KF25 foreline flange	X3511-68001								
Medium-TMP KF40 foreline flange	X3511-68002								

\*For a complete list of available extension cables, see the [Extension Cables for Turbo Pumps dedicated page](#) on Agilent.com.

# Agilent Turbo Pump Models

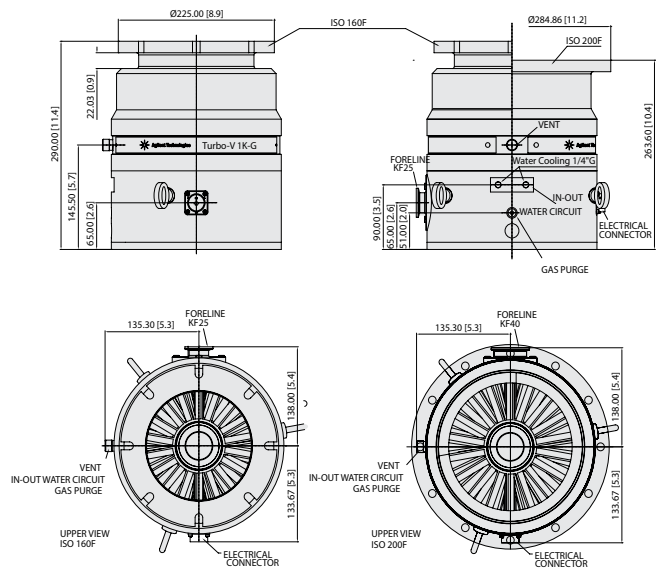

## Turbo-V 1K-G

Dimensions: millimeters [inches]

### Technical Specification

<b>Pumping Speed</b>	Ar: 750 l/s ISO 160 ISO 200	N <sub>2</sub> : 810 l/s N <sub>2</sub> : 1,080 l/s	He: 950 l/s He: 1,150 l/s	H <sub>2</sub> : 680 l/s H <sub>2</sub> : 730 l/s
<b>Compression Ratio</b>	Ar: > 5 x 10 <sup>8</sup>	N <sub>2</sub> : > 5 x 10 <sup>7</sup>	He: > 4 x 10 <sup>4</sup>	H <sub>2</sub> : 1.5 x 10 <sup>4</sup>
<b>Base Pressure* (with minimum recommended forepump)</b>	< 1 x 10 <sup>-10</sup> mbar			
<b>Inlet Flange</b>	ISO 160 F, ISO 200 F			
<b>Foreline Flange</b>	ISO 160 F: KF 25 NW ISO 200 F: KF 40 NW			
<b>Nominal Rotational Speed</b>	45,500 rpm			
<b>Start-Up Time</b>	<5 minutes			
<b>Minimum Recommended Forepump</b>	> 20 m <sup>3</sup> /h (TriScroll 600, DS 602)			
<b>Operating Position</b>	Any			
<b>Operating Ambient Temperature</b>	+5 to +35 °C			
<b>Cooling Requirements</b>	Water			
<b>Bakeout Temperature</b>	80 °C at inlet flange max. (ISO flange)			
<b>Vibration Level (displacement)</b>	< 0.01 μm at inlet flange			
<b>Power Supply</b>	Input voltage: 100-240 Vac Input freq.: 50 - 60 Hz Max input power: 600 VA Stand-by power: 30 to 35 W Max operating power: 400 W t			
<b>Protection Fuse (Navigator controller)</b>	1 x 6.3 A			

**Serial Communication (Navigator Kit)** RS232 cable with a 9-pin D type male connector and a 9-pin D type female connector, and A-PLUS software (optional)

**Storage Temperature** -20 to +70 °C

**Weight** 26.8 kg (59.1 lbs)

\* According to standard DIN 28 428.

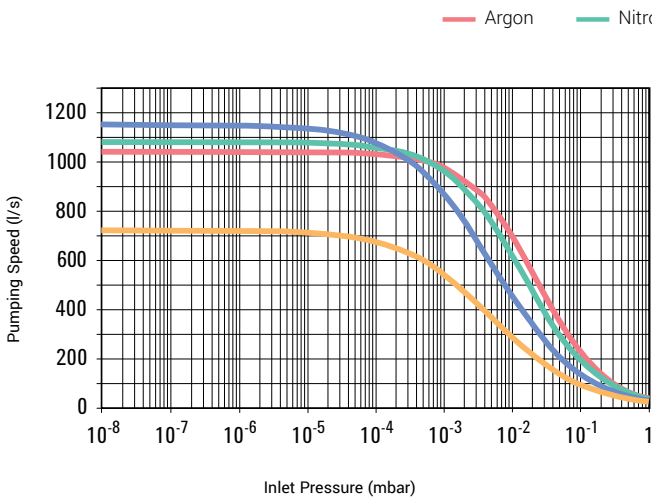

Pumping speed vs inlet pressure

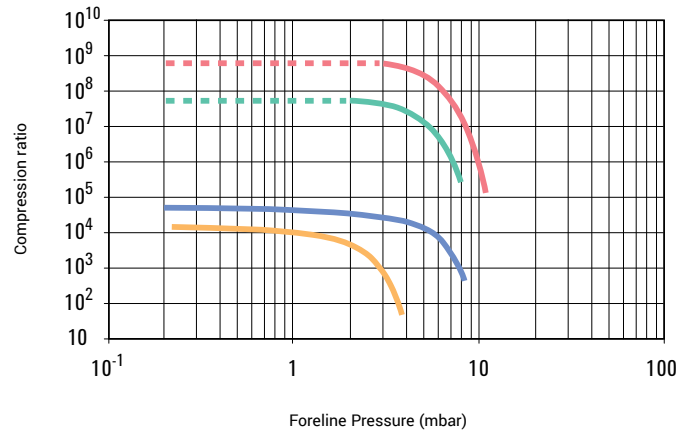

Compression ratio vs foreline pressure

## Ordering Information

Description	Part Number
<b>Pumping Systems</b>	
Turbo-V 1K-G ISO160 F pump	8698961R002
Turbo-V 1K-G ISO200 F pump	8698962R001
<b>Controllers</b>	
Turbo-V 1K-G Navigator controller, 120-220 V	9698978M005
Turbo-V 1K-G rack controller, 100-240 V	X3501-64005
<b>Accessories</b>	
Mains cable NEMA plug, 3 m long	9699958
Mains cable European plug, 3 m long	9699957
Mains cable UK plug, 2.5 m long	X3501-68005
Mains cable China plug, 3 m long	X1699-64144
RS232 serial cable and A-PLUS software, 3 m long	9699883
Inlet screen ISO 160	9699304
Inlet screen ISO 200	9699316
Water cooling kit (hose tail G ¼)	9699825
Water cooling kit (Inox G ¼)	9699826
Vent flange, NW 10 KF / M8	9699108
Vent valve kit, normally open, with 5 m cable, for pumps driven by rack controllers	X3501-68002
Vent valve kit, normally open, with 0.6 m cable, for pumps driven by onboard controllers	9699834

Purge valve KF16-M12 20 SCCM	9699241
Purge valve 20 SCCM ¼ Swagelok - M12	9699242
<b>Recommended Forepump</b>	
Rotary Vane pump DS 602, with 1 ph, worldwide motor	9499335
Rotary Vane pump DS 602, with 3 ph, worldwide motor	9499336
Dry pump TriScroll 600, with 1 ph, worldwide motor	PTS06001UNIV
Dry pump TriScroll 600, with 3 ph, worldwide motor	PTS06003UNIV
Dry pump TriScroll 600 inverter, with 1 ph, worldwide motor	PTS06001INV



## Turbo-V 1001 Navigator

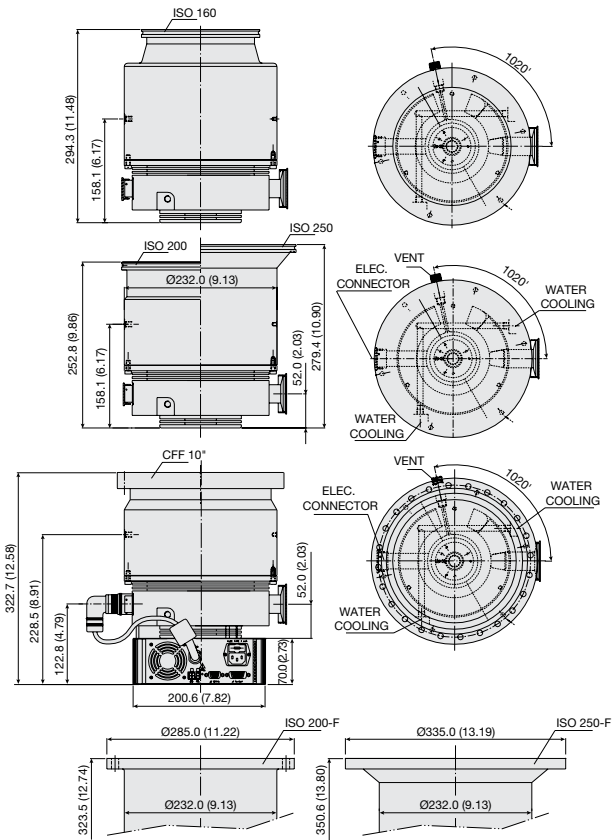

Dimensions: millimeters [inches]

### Technical Specification

<b>Pumping Speed</b>	ISO 160	N <sub>2</sub> : 790 l/s	He: 820 l/s	H <sub>2</sub> : 860 l/s
	CFF 10" or ISO 200	N <sub>2</sub> : 950 l/s	He: 870 l/s	H <sub>2</sub> : 900 l/s
	ISO 250	N <sub>2</sub> : 1,050 l/s	He: 900 l/s	H <sub>2</sub> : 920 l/s
<b>Compression ratio</b>		N <sub>2</sub> : 1 x 10 <sup>9</sup>	He: 1 x 10 <sup>7</sup>	H <sub>2</sub> : 1 x 10 <sup>6</sup>
		N <sub>2</sub> : 1 x 10 <sup>9</sup>	He: 1 x 10 <sup>7</sup>	H <sub>2</sub> : 1 x 10 <sup>6</sup>
<b>Base Pressure* (with minimum recommended forepump)</b>	<1 x 10 <sup>-10</sup> mbar (< 1 x 10 <sup>-10</sup> Torr)			
<b>Inlet Flange</b>	ISO 160, ISO 200-K, ISO 200-F bolted, CFF 10", ISO 250-K, ISO 250-F			
<b>Foreline Flange</b>	KF 40			
<b>Rotational Speed</b>	38,000 rpm			
<b>Start-Up Time</b>	<4 minutes			
<b>Recommended Forepump</b>	Mechanical: Agilent DS 402 Dry scroll: Agilent TS300, IDP-15			
<b>Operating Position</b>	Any			
<b>Cooling Requirements</b>	Forced air or water			
<b>Bakeout Temperature</b>	120 °C at inlet flange max. (CFF flange)			
	80 °C at inlet flange max. (ISO flange)			
<b>Vibration Level (displacement)</b>	< 0.01 µm at inlet flange			

\*According to standard DIN 28 428

<b>Weight kg (lbs):</b>	ISO 160 flange	19 (41.8)
	ISO 200 flange	19.4 (43.0)
	CFF 10" flange	25.5 (54.2)
	ISO 250 flange	21.2 (46.6)

Available with On-board Navigator controller, ½ rack controller or PCB controller; for information on controllers see also following pages.

SEM version available on request.

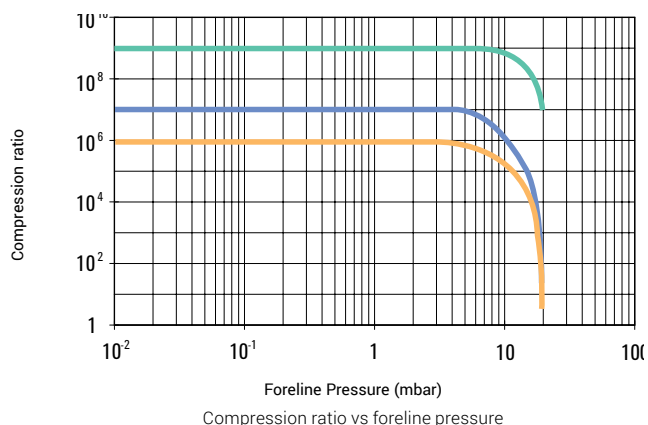
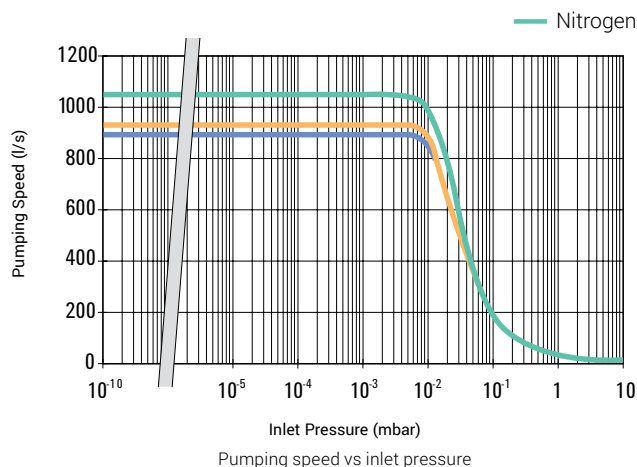

## Ordering Information

Description	Part Number
<b>Complete Systems</b>	
Turbo-V 1001 Navigator complete system, ISO 160 flange	9698840
Turbo-V 1001 Navigator complete system, ISO 200 flange	9698838
Turbo-V 1001 Navigator complete system, ISO 200-F bolted flange	9698844
Turbo-V 1001 Navigator complete system, 10" CFF flange	9698839
Turbo-V 1001 Navigator complete system, ISO 250 flange	9698841
Turbo-V 1001 Navigator complete system, ISO 250-F bolted flange	9698845
<i>Complete system includes: Pump, inlet screen, controller mounted on the bottom, 2 Mains cables (NEMA plug and European plug).</i>	
<b>Pumps</b>	
<b>Turbo-V 1001 Navigator Pump, ISO 160 flange</b>	9698933
Turbo-V 1001 Navigator Pump, ISO 200 flange	9698931
Turbo-V 1001 Navigator pump, ISO 200-F bolted flange	9698946
<b>Turbo-V 1001 Navigator Pump, 8" CFF flange</b>	9698932M003
Turbo-V 1001 Navigator pump, 10" CFF flange	9698932
Turbo-V 1001 Navigator pump, ISO 250 flange	9698934
Turbo-V 1001 Navigator pump, ISO 250-F bolted flange	9698947
<b>Controllers</b>	
Turbo-V 1001 Navigator controller 120/220 V - 50/60 Hz	9698978
Turbo-V 1001 rack controller, 100-240 V	X3501-64003
<b>Pump Accessories</b>	
Mains cable NEMA plug, 3 m long	9699958
Mains cable European plug, 3 m long	9699957
Mains cable UK plug, 2.5 m long	X3501-68005
Mains cable China plug, 3 m long	X1699-64144

RS232 serial cable and A-PLUS software, 3 m long	9699883
	9699948 (3 m)
	9699948M001 (5 m)
	9699948M002 (20 m)
	9699948M003 (10 m)
Extension cables*	9699948M004 (15 m)
	9699948M005 (30 m)
	9699948M009 (75 m)
	9699948M010 (100 m)
	9699948M011 (65 m)
Inlet screen DN 160	9699304
Inlet screen DN 200	9699316
Inlet screen DN 250	9699350
Water cooling kit	9699337
Plastic water cooling kit	9699347
Air cooling kit for use with Navigator controller	9699297
Air cooling kit for use with standard rack controller	X3501-68001
Vibration damper ISO 160	9699345
Vibration damper, ISO 200	9699346
Vibration damper, CFF 10"	9699336
Vent flange, NW 10 KF / M8	9699108
Vent device with adjustable delay time for standard rack controller	9699831
Vent valve kit, normally open, with 5 m cable, for pumps driven by rack controllers	X3501-68002
Vent valve kit, normally open, with 0.6 m cable, for pumps driven by onboard controllers	9699834
Purge valve 10 SCCM NW16KF - M12	9699239
Purge valve 10 SCCM ¼ Swagelok - M12	9699240
Purge valve 20 SCCM NW16KF - M12	9699241
Purge valve 20 SCCM ¼ Swagelok - M12	9699242
Purge valve 10 SCCM ¼ Swagelok - 7/16 Swagelok	9699232
Purge Valve 20 SCCM ¼ Swagelok - 7/16 Swagelok	9699236
<b>Mounting</b>	
Side mounting bracket for Navigator controller	9699298

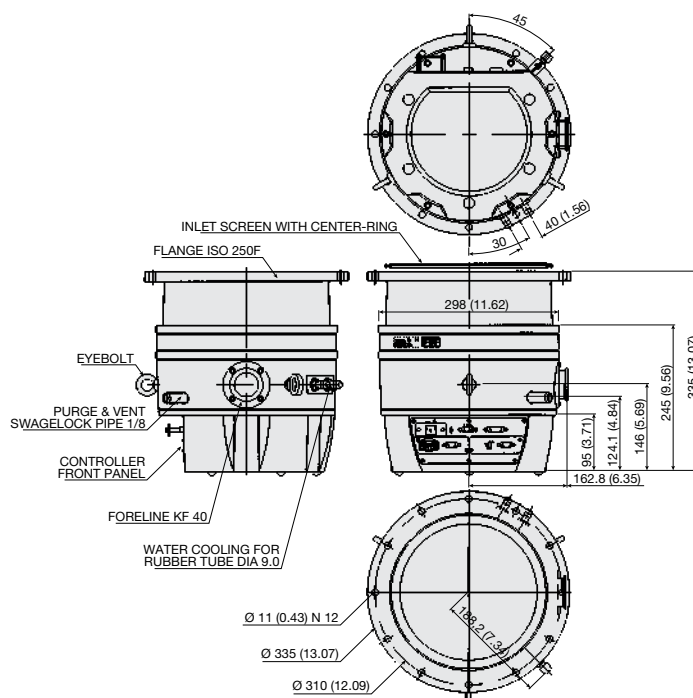

## Turbo-V 2K-G System

Dimensions: millimeters [inches]

### Technical Specification

<b>Pumping Speed</b>	
N <sub>2</sub>	1.600 l/s
<b>Compression Ratio</b>	
N <sub>2</sub>	3 x 10 <sup>5</sup>
<b>Base Pressure* (with minimum recommended forepump)</b>	
	< 1 x 10 <sup>-9</sup> mbar
<b>Inlet Flange</b>	
	ISO 250 F
<b>Foreline Flange</b>	
	KF 40 NW
<b>Rotational Speed</b>	
	33.300 rpm
<b>Start-Up Time without Gas Load and with the Recommended</b>	
	< 7 minutes
<b>Recommended Forepump</b>	
	> 40 m <sup>3</sup> /h
<b>Operating Position</b>	
	Any
<b>Operating Ambient Temperature</b>	
	+5 to +40 °C
<b>Power Supply</b>	
Input voltage	100 - 240 Vac
Input freq.	50 - 60 Hz
<b>Communication Interface</b>	
Analogue I/O	Standard
RS232 / RS485	Standard
Profibus	Optional
<b>Dimensions</b>	
Height	335 mm (13.18 in.)
Diameter	335 mm (13.18 in.)
Weight	35 kg (77 lbs)

\* According to standard DIN 28 428.

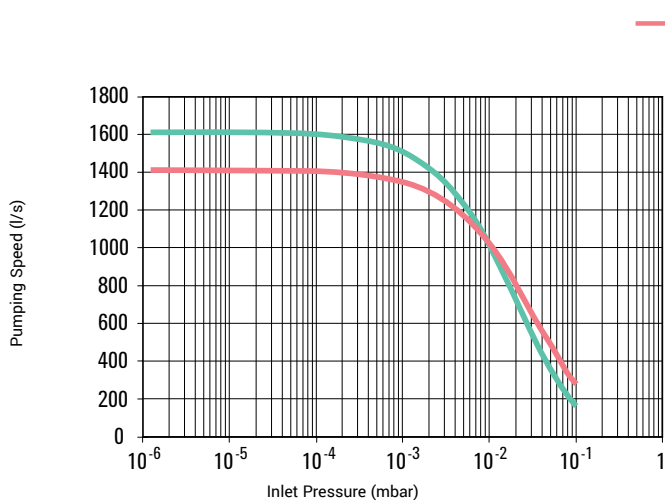

Pumping speed vs inlet pressure

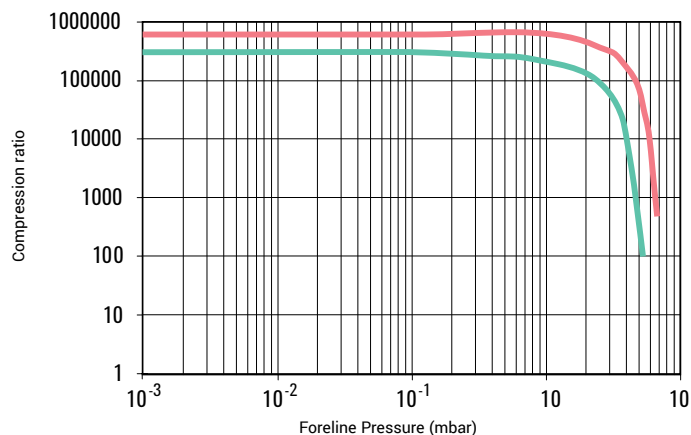

Compression ratio vs foreline pressure

## Ordering Information

Description	Part Number
<b>Pumping Systems*</b>	
Turbo-V 2K-G system	9698871
Turbo-V 2K-G system with Profibus	9698873
*Pumping Systems include Pump with 230 V integrated electronics, water hose connection, inlet screen with center-ring and pre-installed IP54 mating connectors. both standard models can be equipped with Agilent's MoniTorr device on request. Also 120 Vac units available on request.	
<b>Accessories</b>	
Mains cable NEMA plug, 3 m long	9699958
Mains cable European plug, 3 m long	9699957
Mains cable UK plug, 2.5 m long	X3501-68005
Mains cable China plug, 3 m long	X1699-64144
RS232 serial cable and A-PLUS software, 3 m long	9699883
Water cooling kit for 6x8 (IDxOD) flexible tube	9699348
Water cooling kit for 3/8 in. id flexible tube	9699338
Turbo-V remote cable	9699945
Turbo-V remote panel	9698850
Inlet screen ISO 250 with centering ring	9699138
<b>Spare Parts</b>	
IP54 proof mating connectors	9699958
Water hoses	9699825



## Turbo-V 2300 TwisTorr

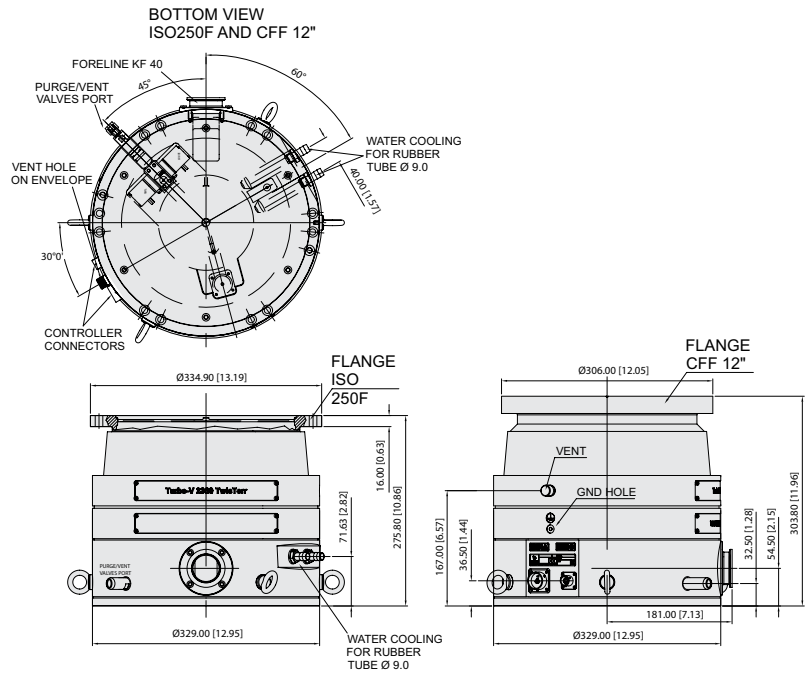

Dimensions: millimeters [inches]

### Technical Specification

<b>Pumping Speed</b>	
N <sub>2</sub>	2050 l/s
He (*)	1800 l/s
H <sub>2</sub> (*)	1500 l/s
<b>Compression Ratio</b>	
N <sub>2</sub>	>8 x 10 <sup>8</sup>
He	8 x 10 <sup>5</sup>
H <sub>2</sub>	4 x 10 <sup>4</sup>
<b>Base Pressure* (with minimum recommended forepump)</b>	
	10 <sup>-10</sup> mbar (7.5 x 10 <sup>-11</sup> Torr) (**)
<b>Max Foreline Pressure for N<sub>2</sub></b>	4 mbar
<b>Inlet Flange</b>	ISO 250F, CFF 12" O.D.
<b>Foreline Flange</b>	KF 40 NW
<b>Rotational Speed</b>	33.300 rpm
<b>Start-Up Time without Gas Load and with the Recommended</b>	< 6 minutes
<b>Recommended Forepump</b>	TriScroll 600
<b>Operating Position</b>	Vertical/Upside down
<b>Operating Ambient Temperature</b>	+5 °C to +35 °C
<b>Bakeout Temperature</b>	120 °C (CFF), 80 °C (ISO)
<b>Max Rotor Temperature</b>	120 °C
<b>Vibration Level (displacement)</b>	< 0.01 μm at inlet flange
<b>Lubricant</b>	Permanent lubrication
<b>Cooling Requirements</b>	Water

<b>Coolant water</b>	Recommended flow: 200 l/h Temperature: +15 to +30 °C Pressure: 3 to 5 bar (45 to 75)
<b>Noise level</b>	<60 dB(A) at 1 meter
<b>Storage Temperature</b>	-20 °C to +70 °C
<b>Environment protection</b>	IP54
<b>Weight</b>	ISO 250: 54.2 kg (119.5 lbs) CFF 12": 55.3 kg (121.9 lbs)

(\*)Without inlet screen

(\*\*)According to standard DIN 28 428, the base pressure is that measured in a leak-free test dome, 48 hours after the completion of test dome bake-out, with a Turbopump fitted with a CFF flange and using the recommended pre-vacuum pump

### Controller Specifications

<b>Input Voltages 1-phase</b>	100-120 VAC, 220-240 Vac,
<b>Input Frequency</b>	50 - 60 Hz
<b>Maximum Input Power</b>	1300 VA
<b>Output Voltage</b>	64 Vac
<b>Output Frequency</b>	555 Hz
<b>Output Power Starting</b>	560 W maximum
<b>Output Power Normal</b>	450 W maximum
<b>Weight (both models)</b>	12.5 kg (28 lbs)
<b>Installation Category</b>	II
<b>Pollution Degree</b>	2

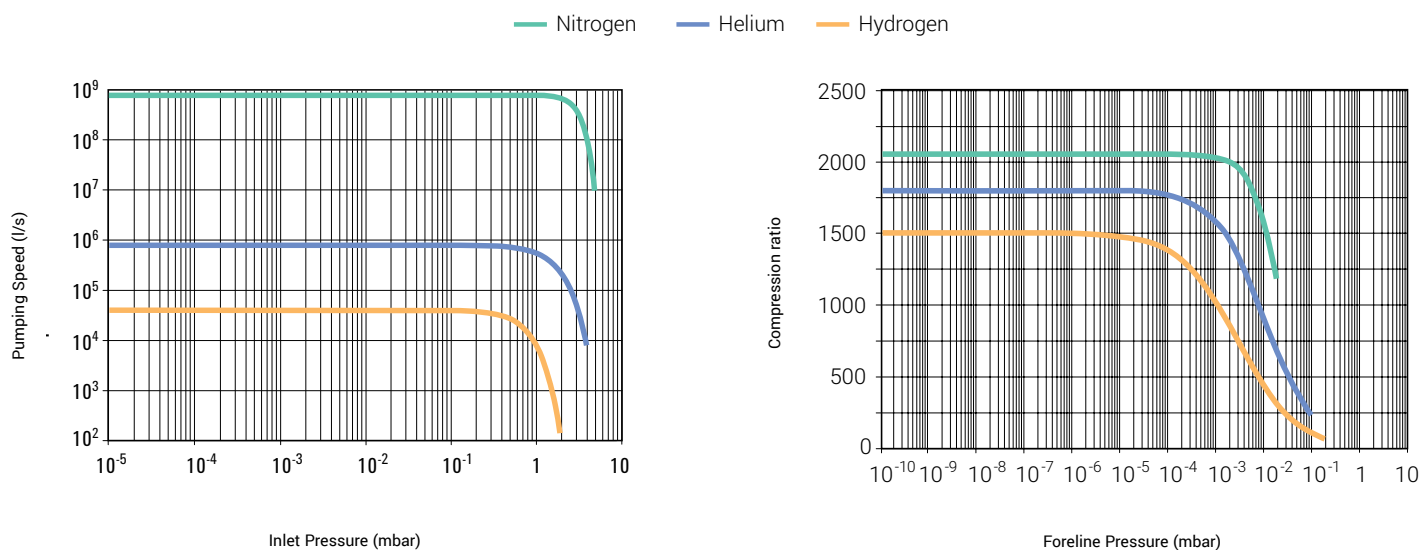

Pumping speed vs inlet pressure

Compression ratio vs foreline pressure

## Ordering Information

Description	Part Number
<b>Pump</b>	
Agilent Turbo-V 2300 TwisTorr ISO250F	9696000
Agilent Turbo-V 2300 TwisTorr CFF12" OD	9696001
<b>Controllers</b>	
Agilent Turbo-V 2300 rack controller, 100-240 V	X3501-64004
Agilent Turbo-V 2300 Pump-controller cable kit, 5 m, for pump and vent valve operation	X3501-68003
<i>(*) Order controller-to-pump cable kit separately</i>	
<b>Accessories*</b>	
Mains cable NEMA plug, 3 m long	9699958
Mains cable European plug, 3 m long	9699957
Mains cable UK plug, 2.5 m long	X3501-68005
Mains cable China plug, 3 m long	X1699-64144
Centering ring, ISO 250	9699144
Inlet screen ISO 250	9699350
Water cooling kit for 6x8 (IDxOD) flexible tube	9699348
Water cooling kit for 3/8 in. ID flexible tube	9699338
Purge valve 20 SCCM ¼ Swagelok ¼ Swagelok	9699236

\*For a complete list of available extension cables, see the [Extension Cables for Turbo Pumps dedicated page](#) on Agilent.com.

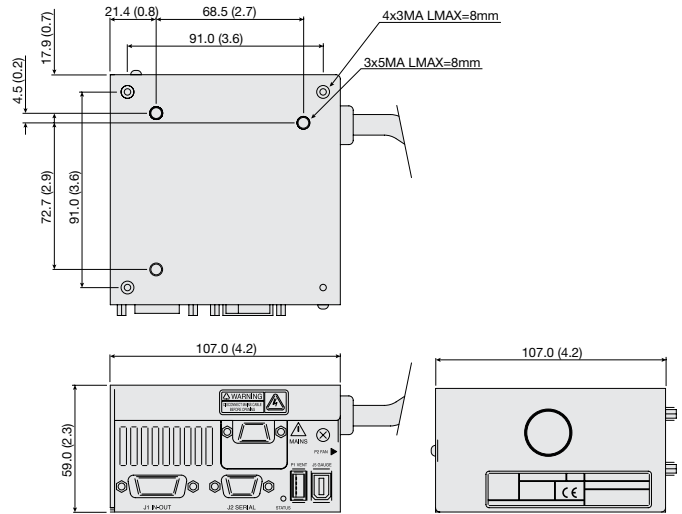

Dimensions: millimeters [inches]

## TwisTorr 74/84 FS On-board Controller

The TwisTorr 74 and 84 FS On-board controller is a solid-state frequency converter with the following features:

- Drives the TwisTorr 84 FS pumps.
- Powers the pump cooling fan.
- Drives the vent valve.
- Provides and acquires the pressure of the wide range gauge.
- Remote I/Os compatible with the previous version.
- Navigator default serial compatible with the previous RS 232 and 485 version.
- Able to operate with active gauges (full range gauge FRG-700 and FRG-702).

The dedicated controller is a solid-state frequency converter which is driven by a single chip microcomputer and consists of two PCBs which include power supply and 3-phase output, analog and input/output section, microprocessor and digital section.

The power supply, together with the 3-phase output, converts the single phase AC mains supply or 24Vdc supply into a 3-phase, low voltage, medium frequency output which is required to power the pump. The controller can be operated by a remote host computer via the serial connection.

Windows-based software is available (optional).

The TwisTorr 74 and 84 FS AG Navigator controller can be mounted on board, on the bottom of the TwisTorr 74 and 84 FS pumps.

### Technical Specification

<b>Input Voltages:</b>		
Navigator controller	24 Vdc	
Navigator controller	100/240 Vac	
<b>Input Power:</b>		
Navigator controller	24 Vdc 80 W	
Navigator controller	100/240 Vac 180 VA	
<b>Input Frequency:</b>		
Navigator controller	100/240 Vac	50 to 60 Hz ±5%
<b>Fuse</b>	2 x T4 A 250 V	
<b>Output Voltage</b>	60 Vac	
<b>Output Frequency</b>	1167 Hz for 74 FS series pumps 1350 Hz for 84 FS series pumps	
<b>Output Power:</b>		
Navigator controller,	24 Vdc	50 W
Navigator controller, (normal and autotuning)	100/240 Vac	70 W (ramp), 50 W
<b>Operating Temperature</b>	+5 ÷ +45 °C 0 – 90% (Not condensing)	
<b>Storage Temperature</b>	-20 to +70 °C 0 – 95%	

### Ordering Information

Description	Weight kg (lbs)	Part Number
<b>Controllers</b>		
TwisTorr 74 FS AG on-board AG controller * 110/220 V		X 3509-64030
TwisTorr 74 FS AG on-board controller 24V		X3509-64021
84FS AG on-board controller* 110/220 V	0.3 (0.66)	X3509-64000
84FS AG on-board controller 24 V		X3509-64001
<i>* Order power cable separately</i>		
<b>Cables</b>		
Mains cable NEMA plug, 3 m lon		9699958
Mains cable European plug, 3 m long		9699957
Serial cable and A-PLUS software		9699883
<b>Active Gauges</b>		
FRG-700 Pirani/IMG combination gauge, KF25		FRG700KF25
FRG-700 Pirani/IMG combination gauge, DN40 CF		FRG700CF35
Gauge connection cable to AG rack controller - 3 m		9699960
Gauge connection cable to AG rack controller - 5 m		9699961

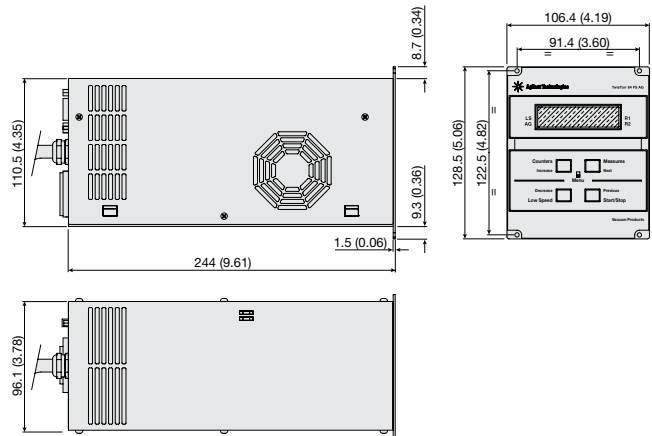

# TwisTorr 74/84 FS AG Rack Controller

Dimensions: millimeters [inches]

The TwisTorr 74 and 84 FS-AG rack controller is a microprocessor-controlled frequency converter with new, enhanced features that allow greater control and communication capabilities.

This compact, ¼ rack unit is designed for full worldwide compatibility, for vent valve control, active gauge pressure reading and pump operation parameters control, as well as for self-diagnostic and protection features.

**Universal Voltage:** Controller able to auto set according to the input voltage, providing flexibility for easy installation worldwide

**RS-232/485 Communication Protocols and Profibus (Options)**

- Allows the pump to be interfaced with the system controls.
- Enables the pump to be operated via PC with A-PLUS software.
- Helps development of own customer software.

**Stop Speed Reading (SSR):**

continues pump speed reading after the stop command

- Allows monitoring the pump in slow down ramp and shut down time.

**N.O. and N.C. Vent Valve Drive:**

- Valve delay and opening time adjustable.
- Vent valve driven by controller automatically or by serial line.
- Opening time control through SSR function.

**Technical Specifications**

<b>Input</b>	100 ÷ 240 Vac 50/60 Hz
<b>Maximum Input Power</b>	210 VA
<b>Output Voltage</b>	76 Vac
<b>Output Frequency</b>	1167 Hz for 74FS series pumps 1350 Hz for 84FS series pumps
<b>Nominal Output Power</b>	100 W
<b>Operating Temperature</b>	+5 to +45 °C
<b>Storage Temperature</b>	-20 to +70 °C

**Active Gauge Pressure Reading Capability:**

- Able to operate with active gauges (full range gauge FRG-700 and FRG-702).
- Provides accurate pressure measurements from atm down to 10<sup>-9</sup> mbar.
- Rack mounted control electronics no longer necessary, with simple +24 Vdc power connector.
- Proven inverted magnetron design.
- Rapid start even in high-vacuum conditions.

**Ordering Information**

Description	Weight kg (lbs)	Part Number
<b>Controller</b>		
TwisTorr 74FS AG rack controller * RS232/485	1.7 (3.2)	X3508-64301
TwisTorr 74FS AG rack controller* Profibus		X3508-64022
TwisTorr 84FS AG rack controller* RS232/485		X3508-64001
TwisTorr 84FS AG rack controller* Profibus		X3508-64002
<i>* Order power cable separately</i>		
<b>Cables</b>		
Mains cable NEMA plug, 3 m long		9699958
Mains cable European plug, 3 m long		9699957
Mains cable UK plug, 2.5 m long		X3501-68005
Mains cable China plug, 3 m long		X1699-64144
RS232 serial cable and A-PLUS software, 3 m long		9699883
<b>Active Gauges</b>		
FRG-700 Pirani/IMG combination gauge, KF25		FRG700KF25
FRG-700 Pirani/IMG combination gauge, DN40 CF		FRG700CF35
FRG-702 Pirani/IMG combination gauge, KF25 All metal - bakeable		FRG702KF25
FRG-702 Pirani/IMG combination gauge, DN40 CF All metal - bakeable		FRG702CF35
Gauge connection cable to AG rack controller, 3 m		9699960
Gauge connection cable to AG rack controller, 5 m		9699961

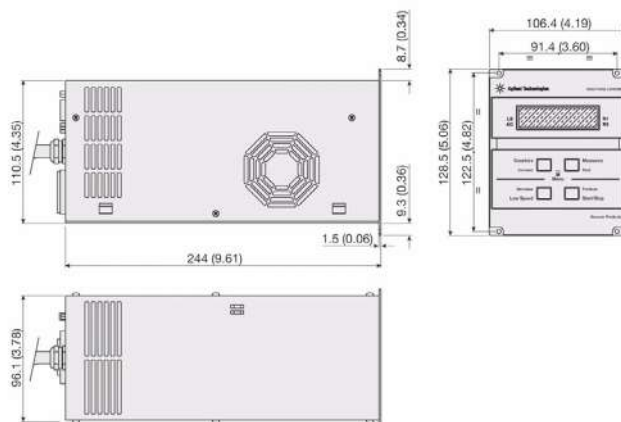

## TwisTorr 305 FS Rack Controller

Dimensions: millimeters [inches]

### Technical Specifications

<b>Input</b>	100 ÷ 240 Vac 50V/60 H
<b>Maximum Input Power</b>	300 VA
<b>Output Voltage</b>	75 Vac
<b>Output Frequency</b>	1010 Hz
<b>Nominal Output Power</b>	150 W
<b>Operating Temperature</b>	+5 to +45 °C
<b>Storage Temperature</b>	-20 to +70 °C

### Ordering Information

Description	Weight kg (lbs)	Part Number
<b>Controllers</b>		
TwisTorr 305 FS AG rack controller* with RS 232/485	1.7 (3.2)	X3506-64002
TwisTorr 305 FS AG rack controller* with Profibus	1.7 (3.2)	X3506-64003
<i>*Order power cable separately</i>		
<b>Cables</b>		
Mains cable NEMA plug, 3 m long		9699958
Mains cable European plug, 3 m long		9699957
Mains cable UK plug, 2.5 m long		X3501-68005
Mains cable China plug, 3 m long		X1699-64144
Replace with: RS232 serial cable and A-PLUS software, 3 m long		9699883
<b>Active Gauges</b>		
PVG-500 Pirani, KF16		PVG500KF16
PVG-500 Pirani tungsten filament, KF16 P		PVG500KF16S
FRG-700 Pirani/IMG combination gauge,		FRG700KF25
FRG-700 Pirani/IMG combination gauge, DN40 CFF		RG700CF35
FRG-702 Pirani/IMG combination gauge, KF25 All metal - bakeable		FRG702KF25
FRG-702 Pirani/IMG combination gauge, DN40 CF All metal - bakeable		FRG702CF35
PCG-750 Pirani/CDG combination gauge (Tungsten), KF16		PCG750KF16
Gauge connection cable to AG rack controller - 3 m		9699961
Gauge connection cable to AG rack controller - 5 m		9699961
<i>NOTE • For other Active Gauges models please ask Agilent for details</i>		

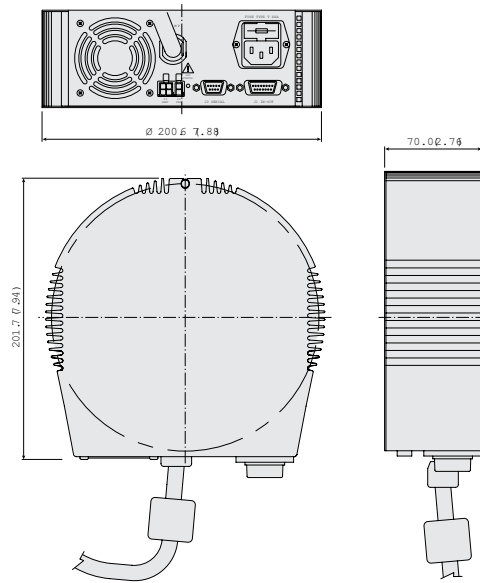

## TwisTorr Medium-TMP Onboard Controller

Dimensions: millimeters [inches]

### Technical Specifications

<b>Input</b>	100-240 VAC 50/60 Hz, 1 ph
<b>Maximum Input Power</b>	600 VA
<b>Output Voltage</b>	54 Vac, 3 ph
<b>Output Frequency</b>	825 Hz
<b>Operating Temperature</b>	+5 to +40 °C
<b>Storage Temperature</b>	-20 to +70 °C

### Ordering Information

Description	Part Number
<b>Controllers</b>	
TwisTorr Medium-TMP onboard controller	X3512-64016
<b>Cables</b>	
Mains cable NEMA plug, 3 m long	9699958
Mains cable European plug, 3 m long	9699957
Mains cable UK plug 2.5 m long	X3501-68005
Mains cable China plug 2.5 m long	X1699-64144
RS232 serial cable and A-PLUS software, 3 m long	9699883

Medium-TMP extension cable	9699948M001 (5 m)
	9699948M003 (10 m)
	9699948M004 (15 m)
	9699948M002 (20 m)
	9699948M005 (30 m)
	9699948M006 (50 m)
	9699948M009 (75 m)
	9699948M010 (100 m)

### Ordering Information

Description	Part Number
<b>Mounting</b>	
Medium-TMP onboard ctrl. side-mounting bracket	X3511-68003
<b>Cooling</b>	
Medium-TMP air cooling kit for onboard controller	9699297
<b>Venting</b>	
Vent valve driven by onboard controller	9699834

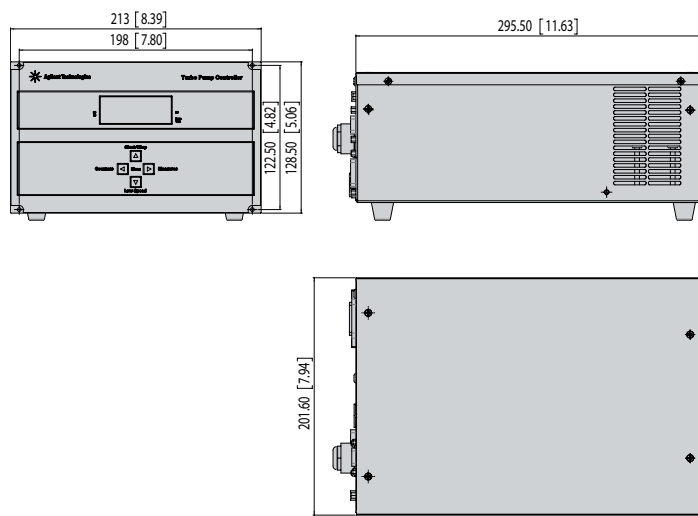

## TwisTorr Medium-TMP Rack Controller

Dimensions: millimeters [inches]

### Technical Specifications

<b>Input</b>	100-240 Vac 50/60 Hz, 1 ph Maximum
<b>Maximum Input Power</b>	800 VA
<b>Output Voltage</b>	54 Vac, 3 ph
<b>Output Frequency</b>	825 Hz
<b>Operating Temperature</b>	+5 to +45 °C
<b>Storage Temperature</b>	-20 to +70 °C

### Ordering Information

Description	Part Number
<b>Controllers</b>	
TwisTorr Medium-TMP rack controller	X3501-64016
<b>Cables</b>	
Mains cable NEMA plug 3 m long	9699958
Mains cable EU plug 3 m long	9699957
Mains cable UK plug 2.5 m long	X3501-68005
Mains cable China plug 2.5 m long	X1699-64144
RS232 serial cable and A-PLUS software, 3 m long	9699883
	9699948M001 (5 m)
	9699948M003 (10 m)
	9699948M004 (15 m)
	9699948M002 (20 m)
Medium-TMP extension cable	9699948M005 (30 m)
	9699948M006 (50 m)
	9699948M009 (75 m)
	9699948M010 (100 m)

### Ordering Information

Description	Part Number
<b>Cooling</b>	
Medium-TMP Air Cooling Kit for rack	X3501-68001
	X3501-68101 (5 m)
	X3501-68051 (10 m)
	X3501-68061 (15 m)
	X3501-68021 (20 m)
Air cooling kit extension cable	X3501-68011 (30 m)
	X3501-68071 (50 m)
	X3501-68081 (75 m)
	X3501-68091 (100 m)
<b>Venting</b>	
Vent valve kit, normally open, with 5 m cable, for pumps driven by rack controllers	X3501-68002
Vent valve kit, normally closed, with 5 m cable, for pumps driven by rack controllers	X3501-68022
	X3501-68004 (5 m)
	X3501-68054 (10 m)
	X3501-68064 (15 m)
	X3501-68074 (20 m)
Vent valve rack extension cable	X3501-68084 (30 m)
	X3501-68034 (50 m)
	X3501-68094 (75 m)
	X3501-68104 (100 m)

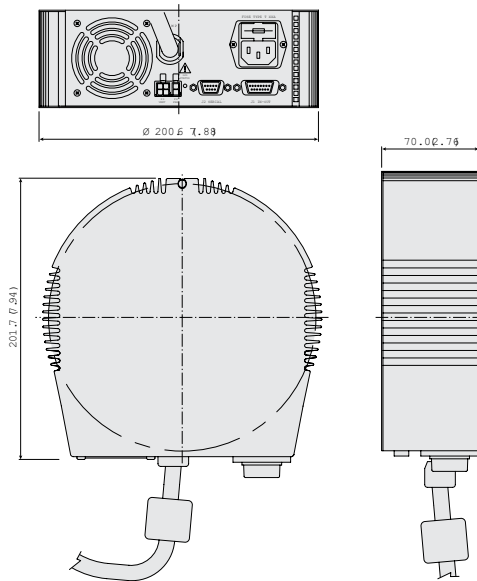

## Turbo-V 1001 Navigator Controller

The Turbo-V 1001 Navigator controllers are microprocessor-controlled frequency converters, fully controllable through PC software, with self-diagnostic and protection features that ensure the highest degree of reliability. They can be mounted on board, either on the bottom or on the side of the pump, offering outstanding flexibility and simplicity.

Dimensions: millimeters [inches]

### Technical Specifications

Input voltages	100/120/220/240 VAC 50/60 Hz, 1 ph
Maximum Input Power	850 VA
Output Voltage	54 VAC, 3 ph
Output Frequency	640 Hz
Operating Temperature	0 to +40 °C
Storage Temperature	-20 to +70 °C

### Ordering Information

Description	Weight kg (lbs)	Part Number
<b>Controllers</b>		
Turbo-V 1001 Navigator controller 120/220 V - 50/60 Hz	3.0 (6.0)	9698978
<b>Accessories</b>		
Mains cable NEMA plug, 3 m long	0.5 (1.0)	9699958
Mains cable European plug, 3 m long	0.5 (1.0)	9699957
Mains cable UK plug, 2.5 m long		X3501-68005
Mains cable China plug, 3 m long		X1699-64144
RS232 serial cable and A-PLUS software, 3 m long	0.5 (1.0)	9699883
External "TMP Profibus gateway"	0.4 (0.8)	9699261
Vent valve kit, normally open, with 0.6 m cable, for pumps driven by onboard controllers		9699834

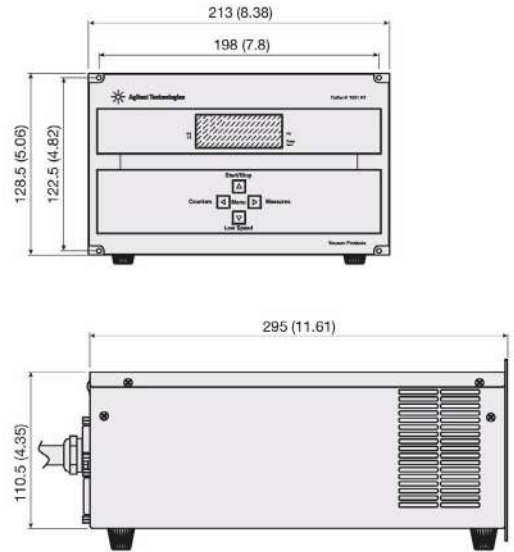

## Turbo-V 1001 Rack Controller

Dimensions: millimeters [inches]

These controllers are microprocessor-controlled frequency converters with self diagnostic and protection features that ensure the highest degree of reliability. The compact, ½ rack unit has a multifunction alphanumeric display for pump status and error code diagnostics.

The front panel has a two-line dot matrix LCD display with back lighting. It displays rotational speed as the pump starts up and indicates when full speed is reached. At any time during the operation of the pump, the speed, current, power, and bearing temperature can be displayed.

Additionally, the microprocessor acts as a pump cycle log, and can display the number of vacuum cycles, the cycle time

for the current cycle, and the total operating hours on the pump. Remote operation can be accomplished with logic level contact closures and with optional computer interfaces.

**PCB controllers are available. Please contact Agilent for details.**

### Ordering Information

Description	Weight kg (lbs)	Part Number
<b>Controllers</b>		
Turbo-V 1001 rack controller, 100-240 V	15.7 (35.0)	X3501-64003
<b>Accessories</b>		
Mains cable NEMA plug, 3 m long		9699957
Mains cable (American plug, 120 V, 3 m long)		9699958
Mains cable UK plug, 2.5 m long		X3501-68005
Mains cable China plug, 3 m long		X1699-64144
<b>Options</b>		
Rack adapter for controller	2.0 (4.0)	9699191
Controller to pump extension cable (5 m extension) for Turbo-V 1001*	1.0 (2.0)	9699948M001
Controller to pump extension cable (20 m extension) for Turbo-V 1001*	4.0 (8.0)	9699948M002
*For different extension cables, see medium rack controller extension cable list		
External "TMP Profibus gateway"	0.4 (0.8)	9699261
Vent valve kit, normally open, with 5 m cable, for pumps driven by rack controllers		X3501-68002

### Technical Specifications

<b>Input</b>	100-240 VAC 50/60 Hz, 1 ph
<b>Maximum Input Power</b>	800 VA
<b>Output Voltage</b>	54 Vac, 3 ph
<b>Output Frequency</b>	825 Hz
<b>Maximum Output Power*</b>	450 W
<b>Startup Power</b>	450 W
<b>Operating Temperature</b>	+5 to +45 °C
<b>Storage Temperature</b>	-20 to +70 °C
* Data valid for nitrogen.	

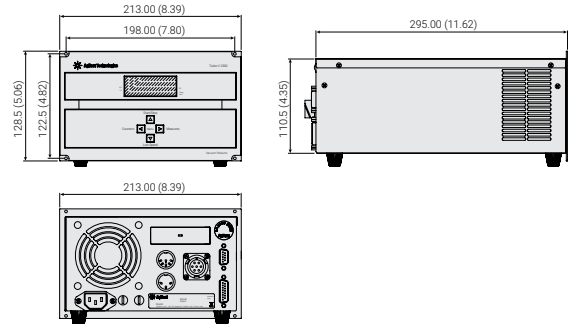

# Turbo-V 2300 Rack Controller

Dimensions: millimeters [inches]

## Technical Specifications

<b>Input</b>	100-120 VAC, 220-240 VAC, 1-phase
<b>Maximum Input Power</b>	1.300 VA
<b>Output Voltage</b>	64 Vac
<b>Output Frequency</b>	555 Hz
<b>Output Power Starting</b>	560 W maximum
<b>Output Power Normal</b>	450 W maximum
<b>Weight (both models)</b>	12.5 kg (28 lbs)
<b>Installation Category</b>	II
<b>Pollution Degree</b>	2

## Ordering Information

Description	Part Number
<b>Controllers</b>	
Agilent Turbo-V 2300 rack controller, 100-240 V	X3501-64004
Agilent Turbo-V 2300 pump-controller cable kit, 5 m, for pump and vent valve operation	X3501-68003
<i>* Controller-to-pump cable kit to be ordered separately</i>	



## Agilent Turbo Pump Accessories

### Inlet Screens

To prevent any possible damage to the pump blades caused by particles falling into the pump, an inlet screen is available as an accessory. The inlet screen is a curved stainless steel mesh. It provides protection against debris larger than 0.7 to 3 mm (depending on the model), while reducing the pumping speed by only about 10%.

For ordering information, see individual pumps.



Sample of inlet Screen

### Air Cooling Kits

A fan is provided as an option for applications requiring forced air flow. The fan is easily installed using the included installation kit. The air cooling kit can be mounted beside or underneath the pump body. The fans for all the other pump models can be installed in a side location only. The maximum allowable ambient temperature for an effective cooling action is 30 °C. To meet the air flow rate specifications, care must be taken not to restrict or cover the space around the fan so that air can flow freely. The operation of the cooling fan is controlled by the turbo controller.

For ordering information, see individual controllers.

### Water Cooling Kits

A water cooling kit is provided to cool the pump when operating at high inlet or high exhaust pressures. The cooling water can be supplied by an open circuit with drainage or a closed-loop refrigerated system.

Care must be taken to secure the tubes to ensure that they do not detach during operation. Four different kits with various tube sizes are available (refer to the table).

Tube Size	Material	Screw Thread	Part Number
4 x 6 mm (ID x OD)	Plastic	1/8 BSP	9699347
6 x 8 mm (ID x OD)	Plastic	1/4 BSP	9699348
1/4" ID	SST	1/8 BSP	9699337
3/8" ID	SST	1/4 BSP	9699338

For ordering information, see individual pumps.

### Vibration Dampers

Highly sensitive equipment such as an electron microscope and certain analytical instruments require extremely low vibration amplitudes. The dampers reduce turbopump vibration amplitude by at least a factor of 10 at their main frequencies.

They are available up to a size of 200 mm (ISO 200 or CFF 10" O.D.).

To effectively decouple the equipment from the pump, the vibration damper must be installed between the connecting flanges.

For ordering information, see individual pumps.

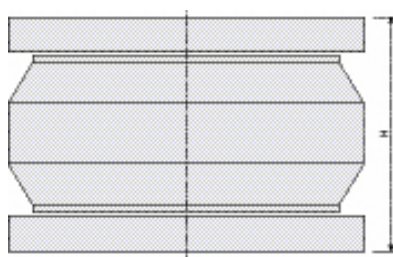

Vibrator damper drawing

	H (mm)	H (in)
Vibration Damper 4 1/2" CF	96.5	3.80
Vibration Damper 6" CF	101	3.97
Vibration Damper 8" CF	110	4.33
Vibration Damper 10" CF	113	4.45
Vibration Damper 63 ISO	84	3.31
Vibration Damper 100 ISO	84	3.31
Vibration Damper 160 ISO	88	3.46
Vibration Damper 200 ISO	88	3.46

### Turbo Vent Valve

The Turbo Vent Valve, consisting of a control unit and a valve, is a complete unit for automatic venting of the turbo pump when it is switched off or during a power failure. The valve is a normally open, electromagnetically-actuated valve with a filter on the air inlet. The control unit is powered by the turbo controller and is provided with a fixed delay time of about 5 seconds to avoid undesired venting during a temporary power failure and to allow closure of the system valves before venting.

For ordering information, see individual controllers.

### Purge Valve

To protect the bearings of a turbomolecular pump used with aggressive process gases, a measured supply of inert gas (N<sub>2</sub>, Ar) must flow into the pump body around the upper bearing toward the fore vacuum line. The Agilent fixed orifice purge valve is calibrated for nitrogen to provide the correct gas flow to safely operate turbo pumps. For ordering information, see individual pumps.

For ordering information, please call your local Agilent Office.



## Turbomolecular Pump Parameters and Definitions

### Throughput

"Throughput" is defined as the flow rate of pumped gas through the turbomolecular pump (and foreline pump). Throughput (Q) is measured in mbar l/s 1/60 standard cm<sup>3</sup>/min.

The maximum throughput a pumping system can handle is, in general, dependent upon the size of its foreline pump rather than the turbomolecular pump.

### Pumping Speed

"Pumping speed" (S) (volumetric flow rate) of a turbomolecular pump is the ratio between throughput and inlet pressure (foreline pump size must be the recommended one as a minimum).

$$S = Q / p$$

The pumping speed of a turbomolecular pump is constant over a wide pressure range and depends upon geometric factors such as diameter and rotational speed. For most turbomolecular pumps, pumping speed is nearly independent from gas species (molecular weight).

### Compression Ratio

"Compression Ratio" is the ratio between foreline (partial) pressure and inlet (partial) pressure for a given process gas, measured in "zero flow" conditions (performed by injecting the process gas in the pump foreline while the high vacuum port is blanked off). Compression ratio is generally indicated with a letter (K). In technical specifications of turbomolecular pumps, it is the maximum attainable value of K (at low foreline pressure).

Compression ratio is, in fact, a function of the foreline pressure as shown in Figure 1.

Compression ratio decays at high pressure depending on turbomolecular pump configuration (the number of molecular stages) and/or power limitations that slow down the rotor (gas friction increases with pressure).

The maximum compression ratio is strongly influenced by gas species: it is an exponential function of the molecular weight of the pumped gas (compression ratio is considerably lower for light gases).

### Pumping Speed and Pressure Ratio

The pressure ratio between foreline and inlet pressures in each operational situation is indicated by "Rp". This is, in general, equal to pumping speed ratio

$$Rp = P_{foreline} / P_{inlet} = S_{eff} / S_{foreline}$$

where "S<sub>eff</sub>" is the effective Pumping Speed, and S<sub>foreline</sub> is the pumping speed of the foreline pump.

In fact

$$Q = S_{eff} p_{inlet} = S_{foreline} p_{foreline}$$

therefore

$$S_{eff} / S_{foreline} = P_{foreline} / P_{inlet}$$

The pumping speed of a turbomolecular pump is minimally affected by pressure ratio (and foreline pump size) in most common operational conditions (when pressure ratio is much smaller than K).

Generally, however, the effective pumping speed "S<sub>eff</sub>" is a linear function of the pressure ratio "Rp" as shown in Figure 2 (and therefore is also dependent upon the size of the backing pump).

S<sub>eff</sub> reaches its maximum value "S" (nominal pumping speed) when "Rp" equals unity, and it is zero when the pressure ratio "Rp" has reached its maximum value "K".

This linear dependence can be expressed by the following relationship:

$$S_{eff} = S / (1 - 1 / K + S / S_{foreline} K) \quad (1)$$

Therefore, when

$$K \gg S / S_{foreline}$$

and

$$K \gg 1$$

then

$$S_{eff} = S \quad \sim$$

when

$$K = 1$$

then

$$S_{eff} = S_{foreline} \quad \sim$$

The above formula (1) must be used to evaluate pumping speed when operating at high pressure, especially with light gases (low K).

## Base Pressure

The base pressure of a turbomolecular pump is the equilibrium pressure between outgassing of pump surfaces exposed to high vacuum, including test dome, and the pumping speed of the pump.

$$P_{base} = Q_{outgas} / S_{eff}$$

In the case of ultimate operational pressure, as specified by norms, the pressure is measured after 48 hours bakeout of pump and dome (provided with metal gasket); therefore the prevailing outgassing product is H<sub>2</sub> and equilibrium is reached with hydrogen pumping speed.

$$P_{base} = Q_{H2} / S_{effH2}$$

When foreline pumps with relatively high base pressures are used, base pressure is sometimes limited by the compression ratio for H<sub>2</sub>O (or N<sub>2</sub>).

$$P_{base} = P_{forelineH2O} / KH2O$$

## Pump Selection

### How to Select a Turbo Pump

The right choice of a turbomolecular pump depends on the application. As a general rule we can reduce the choice to two types of use:

UHV (no gas flow) operations and process gas flow operations.

- **UHV (no gas flow) operations.**

The former case includes most cases in which the turbomolecular pump is employed to create vacuum in systems where the gas load is mainly produced by outgassing. In this application the choice is typically based on the desired base pressure within a desired time as a function of the foreseen outgassing rate, i.e.

$$S_{eff} = Q / p$$

where:

**p** is the desired base pressure (mbar)

**Q** is the total outgassing rate at the desired time (mbar l/s)

**S<sub>eff</sub>** is the effective pumping speed

- **Process gas flow operations.**

The second case relates to all operations where process gases must be used. The main parameters are therefore the desired operation pressure and the process gas flow

$$S_{eff} = Q' / p'$$

where **Q'** is the total gas flow and **p'** is the operating pressure.

### How to Select the Backing Pump of a Turbomolecular Pump

The selection of a backing pump should be based on analyzing two requirements of the vacuum system:

1. **The roughing time**
2. **The minimum recommended backing pump of the turbo**

**1. Roughing:** once the desired roughing time is established, the size of the forepump can be determined through the following formula:

$$S_{foreline} = (V / t) \ln (p0 / p1)$$

where

**S<sub>foreline</sub>** is the pumping speed of the roughing pump (l/min)

**V** is the volume of the chamber to be evacuated (l)

**t** is the desired roughing time (min)

**p0** is the starting pressure (mbar)

**p1** is the end pressure (mbar)

When using a foreline pump much larger than the recommended size, a bypass line might be necessary to achieve calculated roughing time.

**2. Backing:** the backing pump must be big enough to achieve an effective pumping speed as close as possible to the nominal speed.

$$P_{foreline} = Q / S_{foreline}$$

where

**S<sub>foreline</sub>** is the pumping speed of the foreline pump

**Q** is the gas load

**p** is the operating foreline pressure

It should be noted that **Q** is the total gas load on the pump and includes process gases and turbo purge gases when used.

The size of the backing pump can be calculated according to the following rule:

$$S_{foreline} \geq 20S / K$$

where

**S** is the pumping speed of the turbopump

**S<sub>foreline</sub>** is the pumping speed of the backing pump

**K** is the maximum compression ratio of the turbopump for a given gas (i.e.: process gas) at the operating foreline pressure.

The pumping speed of the backing pump should be the higher of the two values calculated as above (roughing and backing).

Finally, it is possible to use a dry pump (scroll or diaphragm) for hydrocarbon-free operation when pumps of the MacroTorr type are used.



## Agilent Molecular Drag Technologies

Pumping stage drag technology enables higher foreline pressure, higher efficiency and allows for a smaller backing pump in a very compact design. Agilent solutions are designed using state of the art, proprietary numerical modeling.

We offer optimized solutions for:

- Pumps with high compression ratio for UHV applications requiring lowest base pressure
- Pumps with high pressure differential for high throughput
- Pumps with high discharge pressure allowing downsizing of the complete vacuum system

**Agilent developed two innovative molecular drag stage technological platforms: TwisTorr and MacroTorr.**

**TwisTorr** for high compression ratio in UHV applications requiring lowest base pressure (no gas flow).



TwisTorr 305-IC cutaway

**MacroTorr** for process gas flow operations with high pressure differential for high throughput.



TwisTorr 305 FSQ cutaway

## TwisTorr technology

- Pumping effect is created by a spinning rotor disk, which transfers momentum to gas molecules.
- Gas molecules are forced to follow spiral groove design on the stator. The specific design of the channel ensures constant local pumping speed and avoids reverse pressure gradients, minimizing power consumption.
- A single TwisTorr stage can improve the compression ratio for  $N_2$  by up to 100 times compared to conventional stages, providing exceptional foreline tolerance and pumping speed.

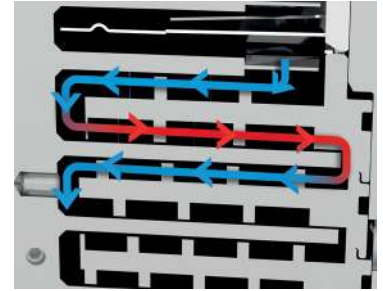

Gas flow in centripetal and centrifugal direction through TwisTorr stages

### Centripetal pumping action

The lower surface area of the rotating disk transfers momentum to gas molecules. The spiral groove design on the upper section of the TwisTorr stator causes a centripetal pumping action.

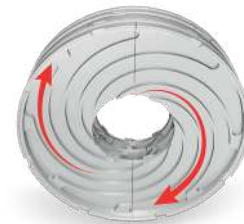

### Centrifugal pumping action

The upper surface area of the rotating disk transfers momentum to gas molecules. The spiral groove design on the lower section of the TwisTorr stator causes a centrifugal pumping action.



## MacroTorr technology

- In the Agilent MacroTorr design, molecular impeller disks replace some of the turbo bladed stages.
- The molecular impellers consist of a disk rotating in a channel where the inlet and outlet are divided by a wall.
- The cross section of the channels decreases from the top to the bottom of the pump (from high vacuum to low vacuum or from the low pressure to the high pressure zone).

Gas molecules gain momentum after each collision with the moving surface of the impeller. The gas is then forced to pass through a hole to the next stage due to the wall.

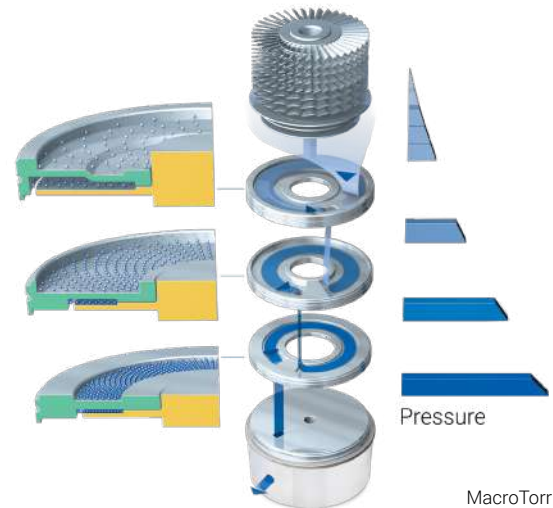

### Designed for high gas load

The MacroTorr pumping stage is designed for operation with very high gas loads. It delivers high sustainable throughput at low operating temperatures in a compact package and extends the foreline tolerance up to 16 mbar.

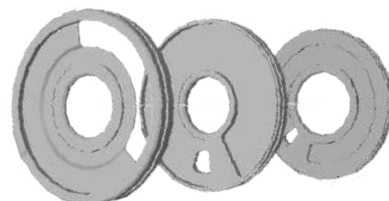

# Agilent Floating Suspension

## Low vibration and stability over time

The Agilent Floating Suspension (AFS) system is a cutting-edge innovation designed to enhance the performance and longevity of turbomolecular pumps. By addressing key aspects such as bearing alignment, rotor dynamics, and noise reduction, the AFS system ensures optimal operating conditions for a wide range of high-precision applications.

### Key Features and Benefits

#### High Geometrical Precision for Perfect Bearing Alignment

The AFS system boasts high geometrical precision, ensuring perfect alignment of the bearings. This precision is crucial for maintaining the integrity and performance of the turbo pump, reducing wear and tear, and extending the operational life of the bearings.

#### Improved Radial and Axial Stiffness

The AFS system enhances both radial and axial stiffness, optimizing the dynamic behavior of the rotor. This improvement leads to better stability and reduced vibrations, which are essential for maintaining the accuracy and reliability of sensitive instruments.

#### Optimized Rotor Dynamic Behavior and Acoustic Noise Reduction

By optimizing the rotor's dynamic behavior, the AFS system minimizes acoustic noise, creating a quieter operating environment. This feature is particularly beneficial in laboratory settings where noise reduction is critical for maintaining a conducive working atmosphere.

#### Low Vibration and Low Acoustic Noise

The AFS system is designed to minimize both vibration and acoustic noise. Low vibration levels are essential for protecting sensitive components and ensuring accurate measurements, while low acoustic noise contributes to a more comfortable and productive working environment.

#### Optimal Working Conditions for Extended Bearing Life

By providing optimal working conditions for the bearings, the AFS system significantly extends their operating life. This longevity reduces maintenance requirements and downtime, leading to increased efficiency and cost savings over the pump's lifecycle.

#### Exceptional Stability for SEM Applications

The AFS system offers exceptional stability, making it ideal for the demanding requirements of scanning electron microscopy (SEM) applications. The enhanced stability ensures precise imaging and analysis, which are critical for high-resolution microscopy.

#### Excellent Thermal Stability

The AFS system provides excellent thermal stability, maintaining consistent performance even under varying temperature conditions. This stability is crucial for applications that require precise control over operating temperatures to ensure accurate results.

The Agilent Floating Suspension system represents a significant advancement in turbopump technology, offering unparalleled precision, stability, and longevity. By incorporating the AFS system, the Agilent turbo pump can achieve superior performance and reliability, ensuring the success of your high-precision applications.

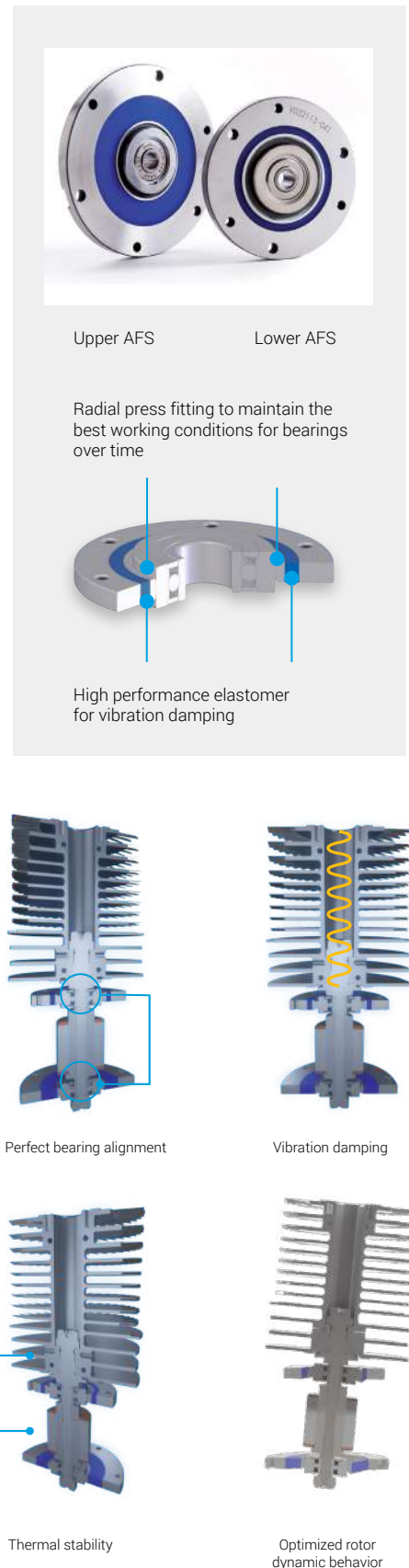

## AI Enabled Adaptive Modal Balancing

### Lower noise and cleaner ultrahigh vacuum

Turbo pumps, which operate at speeds up to 80,000 RPM, are crucial for achieving high vacuum in various applications. To ensure their efficiency and longevity, precise balancing of rotating parts is essential. There are two main balancing techniques: influence-coefficient and modal-based, with modal balancing being the most advanced and precise.

Agilent has implemented an adaptive modal balancing (AMB) technique, using a proprietary algorithm that balances relevant vibration modes across three planes, improving precision and reducing vibration. This new approach integrates key processes into automated software, combining influence-coefficient and modal balancing methods with machine learning.

The Agilent proprietary AI-enabled algorithm continuously monitors the turbo pump balancing parameters all along the manufacturing line. It learns from each successfully balanced pump, analyzing and adjusting the modal balancing parameters to ensure optimal pump performance and production efficiency.

Key advantages: reduced noise, reliable vibration stability in a wider temperature range, and improved quality of turbo pumps. Ultimately the process provides a better customer experience!

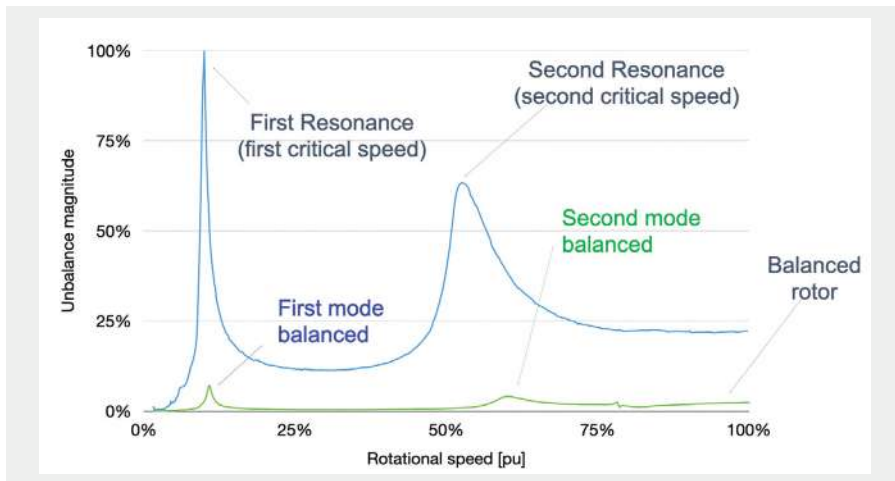
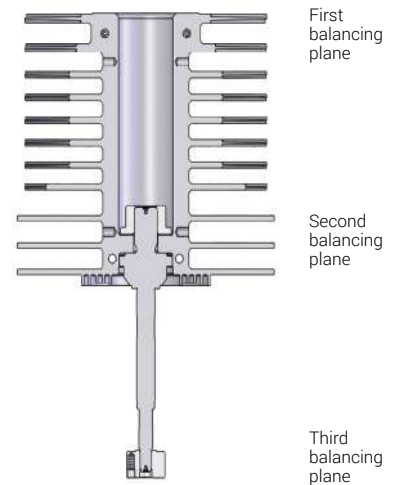

Modal balancing planes rotor locations

#### Modal Balancing vs Influence Coefficient Method

#### Did you Know?

Turbo pump balancing is achieved through the ABM process, which involves adjusting the position of tiny screws on the balancing planes. This method ensures that no material is removed or ablated from any rotating part, eliminating the risk of generating particles or dust. This strategy, inspired by the stringent cleanliness requirements of ion pump technology, is a key part of our manufacturing process.

Agilent turbo pumps are very clean!



## The Vacuum Link App for All Turbo Controllers

Innovation in vacuum control and data sharing



Bluetooth  
remote control



USB direct wire



NFC  
Near field communication



A new way to be connected to your work: export and share device data easily and quickly.



### Tips and tools

Download the new Agilent Vacuum Link app on your smartphone.

Visit <https://www.agilent.com/en/product/vacuum-technologies/vacuum-leak-detection-software/vacuum-link-app> for more.

Compatible with Apple devices only.



# Agilent Vacuum Link App

## A feature-rich app to help speed up the daily tasks.

The Agilent Vacuum Link can monitor up to three TwisTorr 305 pumps at the same time.; A customized "Favorites" page that includes the most important parameters can be created and edited as needed.

Keeping track of pump operation is easy and fast and eliminates the need to sit in front of screen of a controller or a computer for long periods of time.

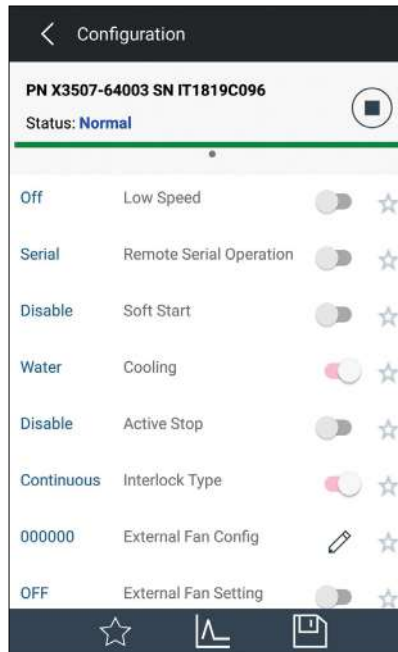

Configure your system

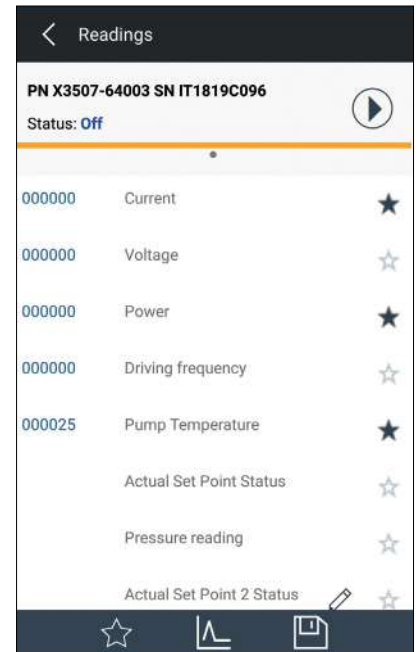

Read the pump parameters

## Control, export, and share data

Creating log files is easy and sharing them is quick using the regular features available on virtually any smartphone.

Log files help users review the pump parameters in a spreadsheet. Plotting parameter variations can be done using the dedicated icon.

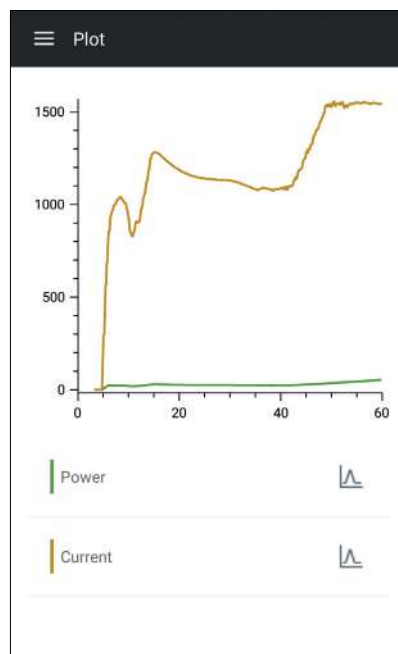

See the pump performance in real time

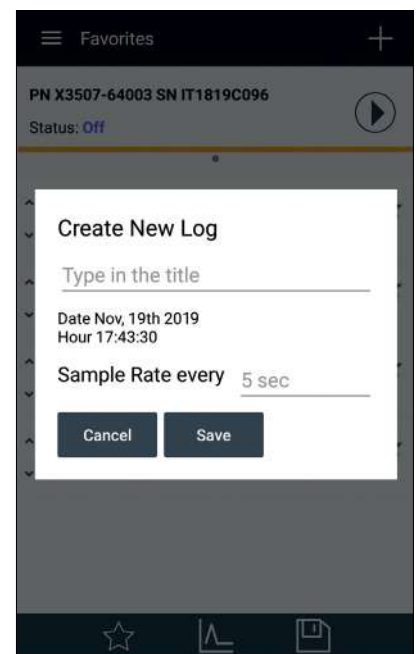

Export and share data

## Agilent A-PLUS

A-PLUS is a communication, control, and monitoring software for controllers associated to selected Agilent products featuring the Agilent Window Serial Protocol.

With A-PLUS, you can simultaneously drive and control one or more Turbo Pumps, connected to a PC through an RS232 or an RS485 serial communication.

Automatic identification of the connected pumps, description of each command always on screen, and user interface adaptable to the pump status are only some of the new features developed to make the approach to pump settings easy and to reduce the number of steps during pump configuration.

Moreover, special care is given to the GUI (graphical user interface), to reproduce the environment of well-known user interfaces (such as Microsoft Windows applications), to obtain a real user friendly tool, and to reduce the user learning time.

A-PLUS software features several options like Data Logging, Chart Representation and Network Configuration, to help you configure your vacuum devices quickly, and to check your vacuum system status at any time.

Exhaustive online help is also included, providing the user with a complete, easy to learn system, tailored to customer requirements.

The previous software release 2.0.2 is included in the A-PLUS CD.



## CE/CSA, EMC Electrical Specifications Compliance

Compliance with these norms guarantees that there are no limits on the use of the controllers and turbopumps in every type of ambient, and that their use doesn't create any kind of disturbance to electronic units connected to the same line.

Agilent's new generation of Turbo controllers comply with the limits given by the following norms:

**EN 55011 Class A group 1**

**EN 61000/3/2**

**EN 61000/3/3**

**EN 61000/4/2**

**EN 61000/4/3**

**EN 61000/4/4**

**EN 61010-1**

**UNI EN 291-1**

**UNI EN 292-2**

**EN 1012-2**

# Agilent Turbo Pump Service and Support Plan

This guide describes service options for your Agilent turbomolecular pump. Service options include exchange, upgrade, diagnostics, rechanneling, repair.

Tables 1 and 2 summarize each service option and provide an overview of the services included. Detailed descriptions of each option are given on the following pages.

**Table 1. Summary of turbo pump service options**

	When to Choose	Includes	Location	Availability	Packaging	Shipping	Warranty
<b>Onsite Diagnostics</b>	All pumps Health check Application consulting	Vibration analysis Fourier analysis Application optimization	Onsite	FSE/AE availability	-	-	-
<b>Rechanneling</b>	Unused pumps only Longer idle periods < 24 months old	Controlled grease distribution Proprietary algorithm for process control Monitoring of power, current, and temperature at predefined frequency steps Rebalancing input, if required Final test and Fourier analysis	Regional service center	<2 weeks	Customer supplied	Pickup and delivery included	-
<b>Fast Track Service</b>	< 5 years of infrequent use Clean applications only Maintenance for pumps that still operate Pump is not crashed	Bearing replacement only	Regional service center	<2 weeks	Customer supplied	Pickup and delivery included	6 months
<b>Repair</b>	Nonfunctional Pump is not crashed	Full pump repair, including cleaning and bearing replacement, balancing, and final test	Regional service center	<2 weeks	Customer supplied	Pickup and delivery included	12 months
<b>Advance Exchange</b>	Nonfunctional Exchange is available Downtime reduction Pump is crashed (plus additional fee)	Fully rebuilt As-new performance and aesthetics	Regional warehouse	From stock	Included	Pickup and delivery included	12 months
<b>Upgrade</b>	Technology refresh Downtime reduction Out of support	Fully rebuilt As-new performance and aesthetics NEW pump option	Regional warehouse	From stock	Included	Pickup and delivery included	12 or 24 months, model dependent

**Table 2. Services included**

	Rechanneling	Fast Track Service	Pump Repair	Pump Exchange
Bearing Conditioning	●	●	●	●
Bearing Replacement		●	●	●
Rotor Balancing	●	●	●	●
Cleaning			●	●
Full Inspection		●	●	●
Helium Leak Check		●	●	●
Vacuum Performance Check		●	●	●
Update to "As-new" Condition			●	●
Two Week Turnaround time (TAT)	●	●	●	
Two day turnaround time (TAT)				●

## Get in touch with the Vacuum Support Team

Prompt, thorough, and accessible support is a core element of the Vacuum Products Technical Support and Service Groups. Our dedicated teams strive to ensure all users get answers to their questions or challenges in a fast and helpful manner.

Contact an Agilent Vacuum Expert using info below or Live Chat.

U.S. and Canada

**Toll free: +1 800 882 7426**

[vpl-customer@agilent.com](mailto:vpl-customer@agilent.com)

Europe/Middle East/Africa

**Tel: +39 011 9979 111**

**Toll free: 00 800 234 234 00**

[vpt-customer@agilent.com](mailto:vpt-customer@agilent.com)

China

**Toll free: 800 820 6778**

[contacts.vacuum@agilent.com](mailto:contacts.vacuum@agilent.com)

India

**Toll free: 1 800 572 3100 (TCL)**

**Toll free: 1 800 102 7906 (Airtel)**

[vpd\\_india@agilent.com](mailto:vpd_india@agilent.com)

Japan

**Tel: +81 120477 111**

[jp-vvt-sales.pdl-ext@agilent.com](mailto:jp-vvt-sales.pdl-ext@agilent.com)

Korea

**Tel: +080 222 2452**

[vpd\\_pdl-sapkbc@agilent.com](mailto:vpd_pdl-sapkbc@agilent.com)

**Fax +39 011-9979-330**

Learn more:

[www.agilent.com/en/product/vacuum-technologies/turbo-pumps-controllers](http://www.agilent.com/en/product/vacuum-technologies/turbo-pumps-controllers)

FAQ:

<https://www.agilent.com/.../turbomolecular-pumps-frequently-asked-questions>

For Turbo Pump Support:

<https://www.agilent.com/cs/library/brochures/br-turbo-pump-service-5994-6644en-agilent.pdf>

Buy online:

[www.agilent.com/store/#quickOrder](http://www.agilent.com/store/#quickOrder)

U.S., Canada and South America

**1-800-882-7426 (toll-free)**

[vpl-customer@agilent.com](mailto:vpl-customer@agilent.com)

Europe

**00 800 234 234 00 (toll-free)**

[vpt-customer@agilent.com](mailto:vpt-customer@agilent.com)

China

**800 820 6778 (toll free, landline)**

**400 820 6778 (toll free, mobile)**

Asia Pacific

[inquiry\\_lsca@agilent.com](mailto:inquiry_lsca@agilent.com)

DE-007591

This information is subject to change without notice.

© Agilent Technologies, Inc. 2025  
Published in the USA, June 16, 2025  
5994-8445EN